

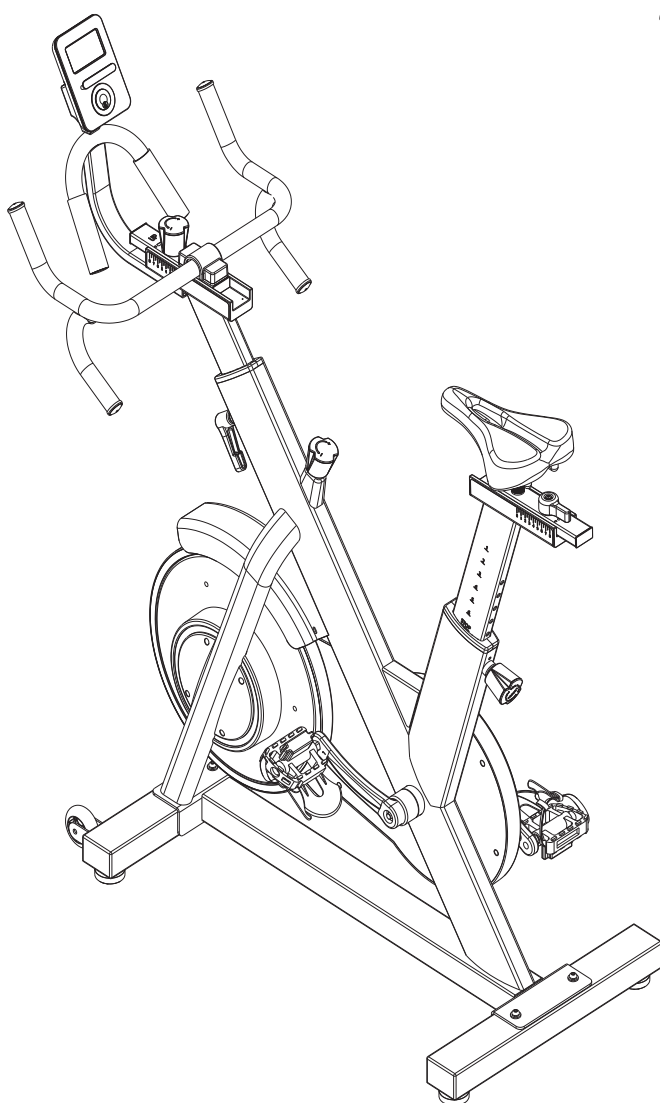

ASSEMBLY MANUAL

PELTEX

SPIN BIKE



Record serial number

Elite Peltex Spin Bike

Thank you for purchasing the **Elite Peltex Spin Bike**.

For over 30 years, Elite Fitness™ has been New Zealand's largest supplier of fitness equipment. Our aim and vision is to provide you Elite™ branded products, tested to the highest standard for quality and biomechanics at the best possible price.

Please read through this manual to familiarise yourself with the operation of your new **Elite Peltex Spin Bike**. Doing so will help to insure that you get the most out of your machine, enjoying safe and effective workouts ahead.

Even though we go to great efforts to ensure the quality of each product we produce, occasional errors and or omissions do occur. In any event should you find this product to have either a defective or a missing part, please contact us for a replacement.

SERVICE & WARRANTY

For service and warranty assistance please visit:

www.elitefitness.co.nz/service

Online forms are available for Service, Warranty and Parts requests.

(09) 258 9067

Elite Fitness HQ

28 Morrin Road
St. Johns
Auckland, New Zealand

info@elitefitness.co.nz
0800 2 438 348
www.elitefitness.co.nz

CONTENTS

Important Safety Instructions	3	Exploded Diagram	15
Product Specifications	4	Setting your Spin Bike Up	16
Parts List	5	Care and Maintenance	18
Hardware Package	7	Maintenance Log	19
Assembly Instructions	8	Limited Warranty	20
Assembly Complete	13	Warm-Up Exercise	21
Console User Instructions	14	Training Stages Parts	22

IMPORTANT SAFETY INSTRUCTIONS

The following definition applied to the word “WARNING” when used in this manual:



Used to call attention to POTENTIAL hazards that could result in personal injury or loss of life.

READ ALL INSTRUCTIONS BEFORE USING THE MACHINE

This product has been designed for home use only. Product liability and warranty conditions will not be applicable to products being subjected to professional use or products being used in a commercial environment. e.g Gym Centre

This exercise machine is built for optimum safety. However, certain precautions apply whenever you operate a piece of exercise equipment. Be sure read the entire manual before you assemble or operate your machine. In particular, note the following safety precautions.

- Read all instructions in this manual before using this equipment.
- Use the machine only for its intended use as described in this Manual.
- Inspect and tighten all the loose parts before this equipment is used.
- Keeps hands away from moving parts.
- Keep children and pets away from the machine at all time. DO NOT leave children unattended in the same room with the machine.
- Before using the machine to exercise, always do stretching exercises to properly warm up.
- Inspect the machine before each use; make sure all of the connections are tightly secured.
- Only one person at a time should use the machine.
- If the user experiences dizziness, nausea, chest pain, or any other abnormal symptoms, STOP the workout at once. **CONSULT A PHYSICIAN IMMEDIATELY.**
- Position the machine on a clear, levelled surface. DO NOT use the machine near water or outdoors.
- Always wear appropriate workout clothing when exercising. DO NOT wear robes or other clothing that could become caught in the machine. Sporting shoes are recommended when using the machine.
- Do not place any sharp object around the machine.
- Disabled persons should not use the machine without a qualified person or physician in attendance.
- Never operate the machine if the machine is not functioning properly.

- Only carry out training work on the equipment when it is in perfect working order. Only use original spare parts in the event of a repair.
- Do not use strong solvents for cleaning, and only use the tools supplied, or suitable ones of your own, for any repairs that may be required. Please dispose of the packaging and any parts that have to be replaced subsequently (all parts for the unit) at suitable collecting points or containers with a view to saving the environment.
- DO NOT extend the seat stem past the warning line “Max” when adjusting the seat height.
- Not for therapeutic use.

WARNING: Before beginning any exercise program, consult your physician. This is especially important for persons with pre-existing health problems. The seller assumes no responsibility for personal injury or property damage sustained by or through the use of this product.

SERVICE HINTS: The high quality standard of this product only will be kept if you on a regular basis check all screw-connections and moving parts on proper fitting. Damaged parts have to be changed immediately. During the time of repair the product must not be used by anybody.

IMPORTANT HINTS:

- A) This product has been tested in accordance with the requirements of EN 957-1/A1, EN 957-5, standard, Class HA (HOME USE). The maximum load is limited to 120 KGS.
- B) Parents should be aware of the risk factor of young children playing on fitness equipment unattended. Make sure that the children are instructed properly in the use of the product and in the controlled execution of the different exercise. Misuse of the product could result in serious injury

PRODUCT SPECIFICATIONS

User Weight Capacity:	120 KG
Shipping Weight:	44.5 KG
Net Weight:	38.8 KG







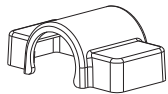
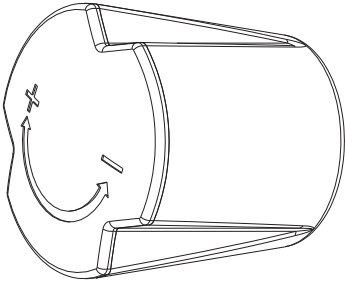

PARTS LIST

No.	Description	Qty.	No.	Description	Qty.
1	Computer	1	33	Rubber Paste 2×29×19	1
2	Computer Holder	1	34	Fixed Plate of Horizontal saddle tube	1
3	Bolt M5*20	4	35	Saddle Tube	1
4	Grommet Φ12.5	2	36L/R	Pedal	1
5	Bolt M8*35*S6	1	37	Knob M16	1
6	Washer d8*φ16*1.5	1	38	Main Frame	1
7	Cap Nut M8*H16*S13	1	39	Bolt Φ7.8*30*M6*15*S5	2
8	Foam Grip φ27*3*120	2	40	Bearing 608ZZ	4
9	End Cap φ28*17	2	41	Roller Φ71*Φ19*24	2
10	Computer Post	1	42	Washer d6*Φ12*1.5	2
11	Trunk Wire 1	1	43	Bolt M6*12*S5	2
12	Bolt M5*18*φ8	12	44	End Cap J50*70	4
13	Bolt M10*25*S8	2	45	Front Stabilizer	1
14	Bolt M8*20*S6	6	46	Nut M8	4
15	Spring Washer d8	6	47	Adjustable Footpad	4
16	Washer d8*φ20*2	6	48	Rear Stabilizer	1
17	Handlebar Join	1	49	Screw ST3*12*φ6	6
18	Handlebar Tube Join	1	50	Cover For Flywheel	2
19	Trunk Wire 2	1	51	Nut M12*1	6
20	L type Handle M16*1.5	1	52	Wave Washer d12*Φ15.5*0.3	3
21	Saddle	1	53	Spacer Φ18*Φ12.1*12.5	1
22	Handle bar cover	1	54	Bearing 6001Z	4
23	Washer d6*φ12*1	1	55	Flywheel	1
24	Handlebar Of Horizontal Saddle Tube	1	56	Flywheel shaft	1
25	Locking Core	1	57	Bolt M5*10*Φ9.5	15
26	Limiter Pin φ3*20	1	58	Front cover	1
27	Bolt M4*12	2	59	Cover	2
28	Limiter	1	60	Bushing	4
29	Rubber φ11*φ8*3	1	61	Bolt ST3*16*φ5.6	8
30	Horizontal Saddle Tube	1	62	Stationary knob	1

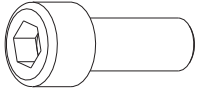
PARTS LIST

31	End Cap J40*20*17	4	63	Brake Rod Cover	1
32	Lower sliding plate	2	64	Bushing	1
65	Bolt $\Phi 10 \times 285 \times M10 \times 15 \times M6 \times 7 \times M10 \times 95$	1	91	Washer d20	1
66	Bushing $\Phi 16 \times \Phi 10.5 \times 78$	1	92	Bearing	2
67	Square Nut M10	1	93	Spacer	1
68	Hexagon Nut M10*H19*S17	1	94	Wave washer d20* $\Phi 26 \times 0.3$	1
69	Nut M6*H14*S10	1	95	Bolt ST4.2*16	10
70	Bolt M6*10	1	96	Inner Cover	1
71	Nylon Nut M10	1	97	Bolt ST4.2*8	1
72	Bolt M6*52	1	98	Belt	1
73	Washer d10* $\phi 20 \times 2$	4	99	Spring Washer d6	4
74	Chain U seat 30*10*1.5	1	100	Magnet	1
75	Nylon Nut M6*H6*S10	7	101	Belt Plate	1
76	Idler Shaft	1	102	Centre Shaft Join	1
77	Idler Pulley	1	103	Bolt M6*16	4
78	Washer d6* $\Phi 16 \times 1.5$	2	104	Outer Cover	1
79	Bolt M6*10	1	105	Ring	1
80	Washer d12	2	106	Sensor	1
81	Magnetic Board Axle	1	107	Grommet	1
82	Bolt M6*45	1	108	Spring washer d10	2
83	Magnet	3	109	Horizontal Handlebar Tube	1
84	Brake Pad 30*20*8	1	110	Fixed Plate of Horizontal Handlebar Tube	1
85	Magnetic Board Join	1			
86	Tension Spring	1	A	Wrench S6	1
87	Crank Cover $\Phi 25 \times 7$	2	B	Spanner S13-14-15	1
88	Nut M10	2	C	Wrench S8	1
89L/R	Crank	1	D	Spanner S13-S15	1
90	Cover	1			

HARDWARE PACKAGE

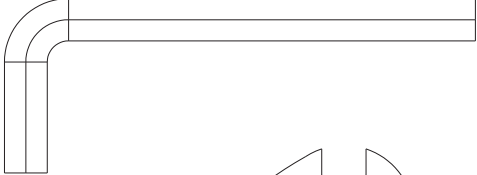
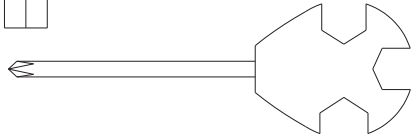
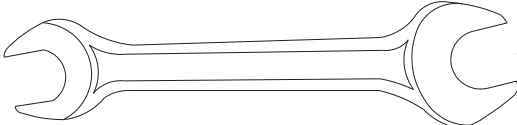
	#22	1PC
	#62 M10	1PC
	#73 d10*Φ20*2	3PCS
	#13 M10*25*S8	2PCS
	#108 d10	2PCS
	#16 d8*Φ20*2	6PCS
	#15 d8	6PCS
	#14 M8*20*S6	6PCS
	#A S6	1PC
	#C S8	1PC
	#B S13-14-15	1PC
	#D S13-15	1PC

ASSEMBLY INSTRUCTIONS

STEP 1

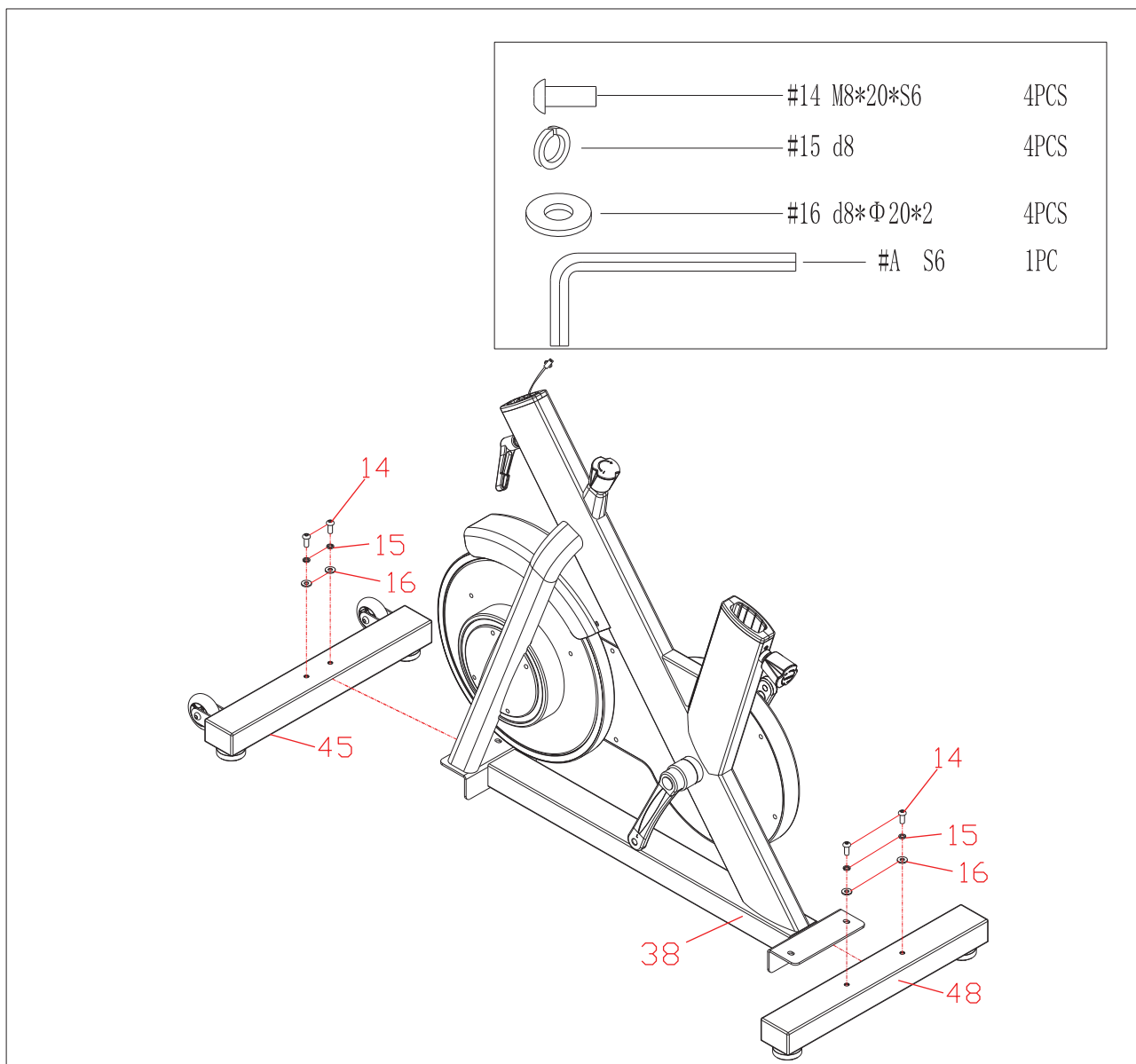

Using wrench (A), remove the bolts (14), spring washers (15), and washers (16) from both the front stabiliser (45) and rear stabiliser (48).

Using wrench (A), fasten the front stabiliser (45) and rear stabiliser (48) to the main frame (38) using the bolts (14), spring washers (15), and washers (16).

ASSEMBLY INSTRUCTIONS

STEP 2

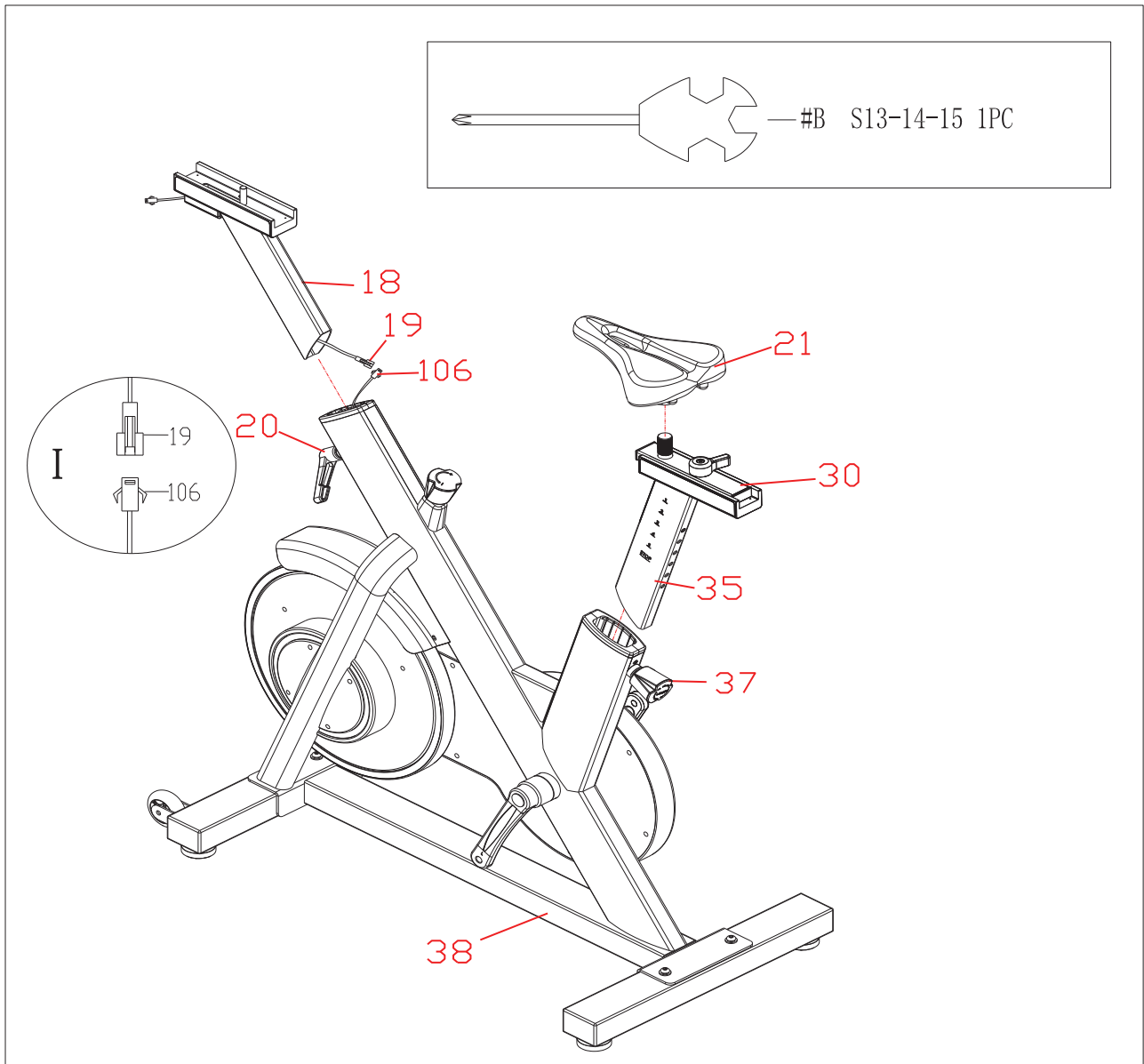

Gently pull the knob (37) partially from the main frame (38). Insert the saddle tube (35) into the main frame (38), adjusting it to the desired position and aligning it with the knob's hole (37). Secure the saddle tube (35) in place within the main frame (38) by tightening the knob (37) securely.

Install the saddle (21) onto the horizontal saddle tube (30), then fasten them together using spanner (B).

Ensure a proper connection between trunk wire 2 (19) and the sensor (106).

Partially retract the L-type handle (20) from the main frame (38). Insert the handlebar tube join (18) into the main frame (38), adjusting it as needed and aligning it with the hole of the L-type handle (20). Secure the handlebar tube join (18) within the main frame (38) by tightening the L-type handle (20) firmly.

ASSEMBLY INSTRUCTIONS

STEP 3

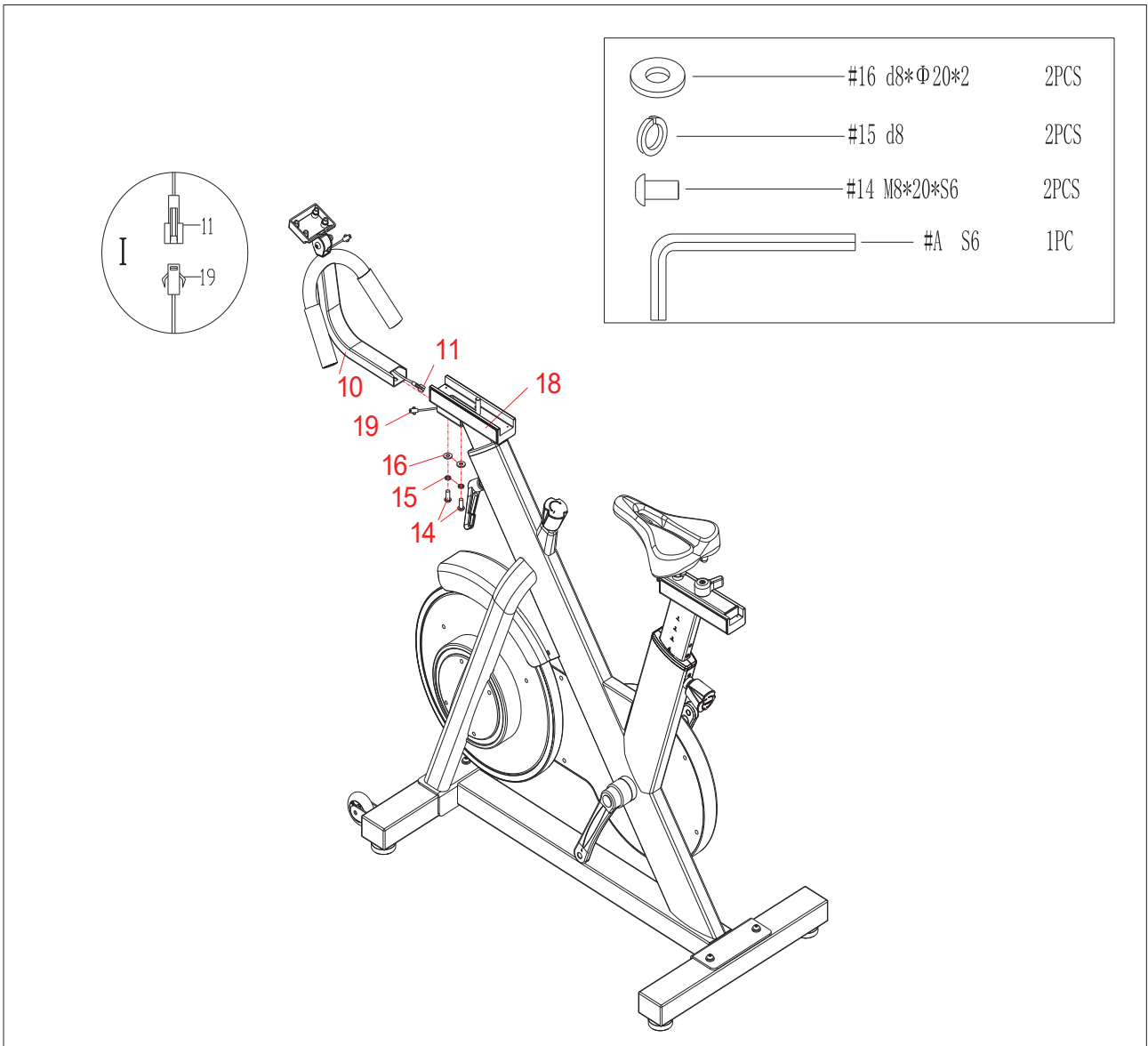

Using wrench (A), carefully remove the bolts (14), spring washers (15), and washers (16) from the handlebar tube join (18).

Ensure a secure connection between trunk wire 1 (11) and trunk wire 2 (19).

Insert the wire into the computer post (10), then insert the computer post (10) into the handlebar tube join (18). Secure them together using the bolts (14), spring washers (15), and washers (16), tightening them with wrench (A).

ASSEMBLY INSTRUCTIONS

STEP 4

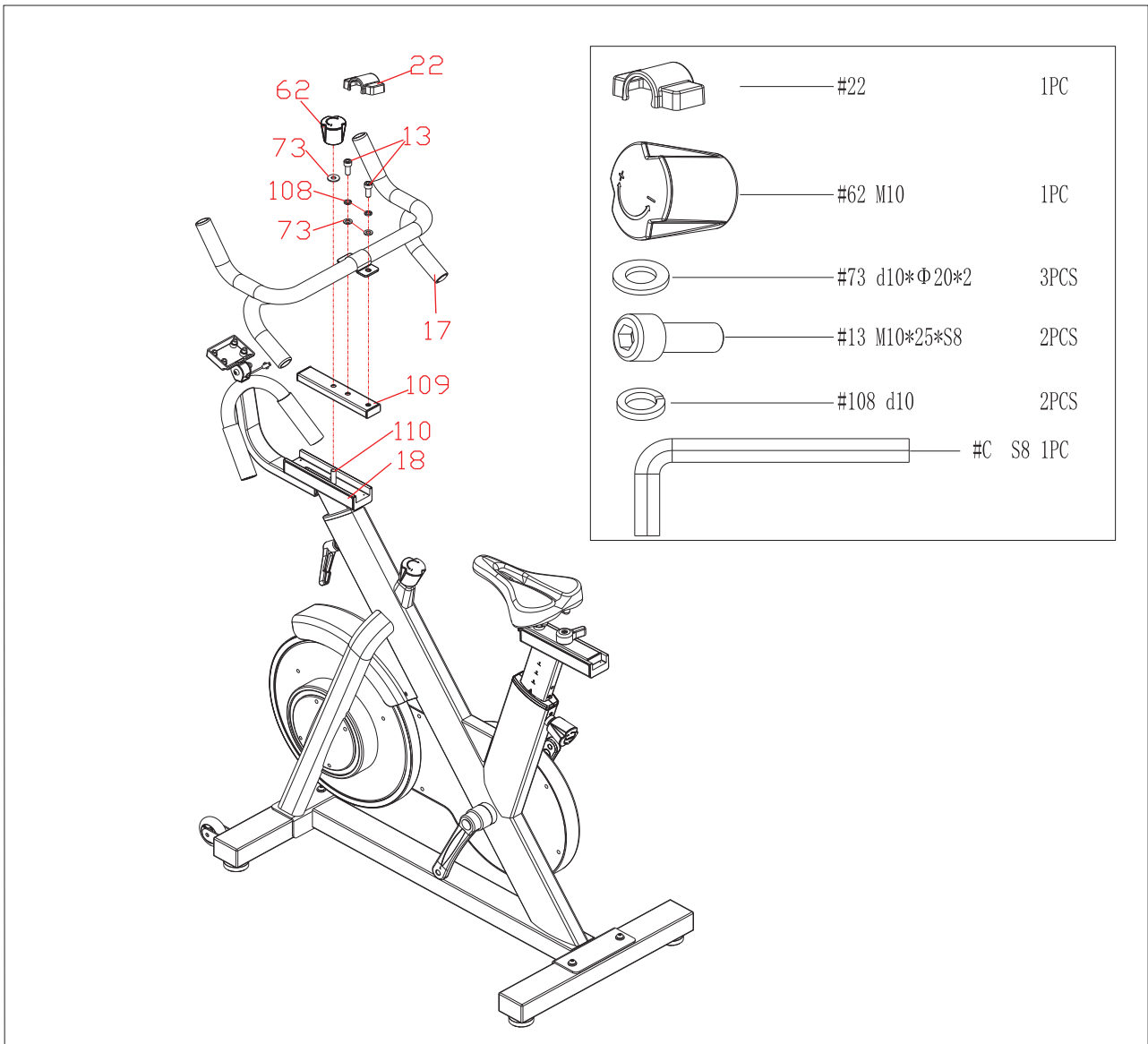

Using spanner (B), carefully remove the bolts (13), spring washer (108), and washers (73) from the horizontal handlebar tube (109).

Insert the horizontal handlebar tube (109) into the fixed plate of the horizontal handlebar tube (110), aligning the holes. Secure them onto the handlebar tube join (18) using the knob (62) and washer (73).

Place the handlebar join (17) onto the horizontal handlebar tube (109). Secure the handlebar join (17) within the horizontal handlebar tube (109) using the bolts (13), spring washers (108), and washers (73) with wrench (C). Then, attach the cover (22).

ASSEMBLY INSTRUCTIONS

STEP 5

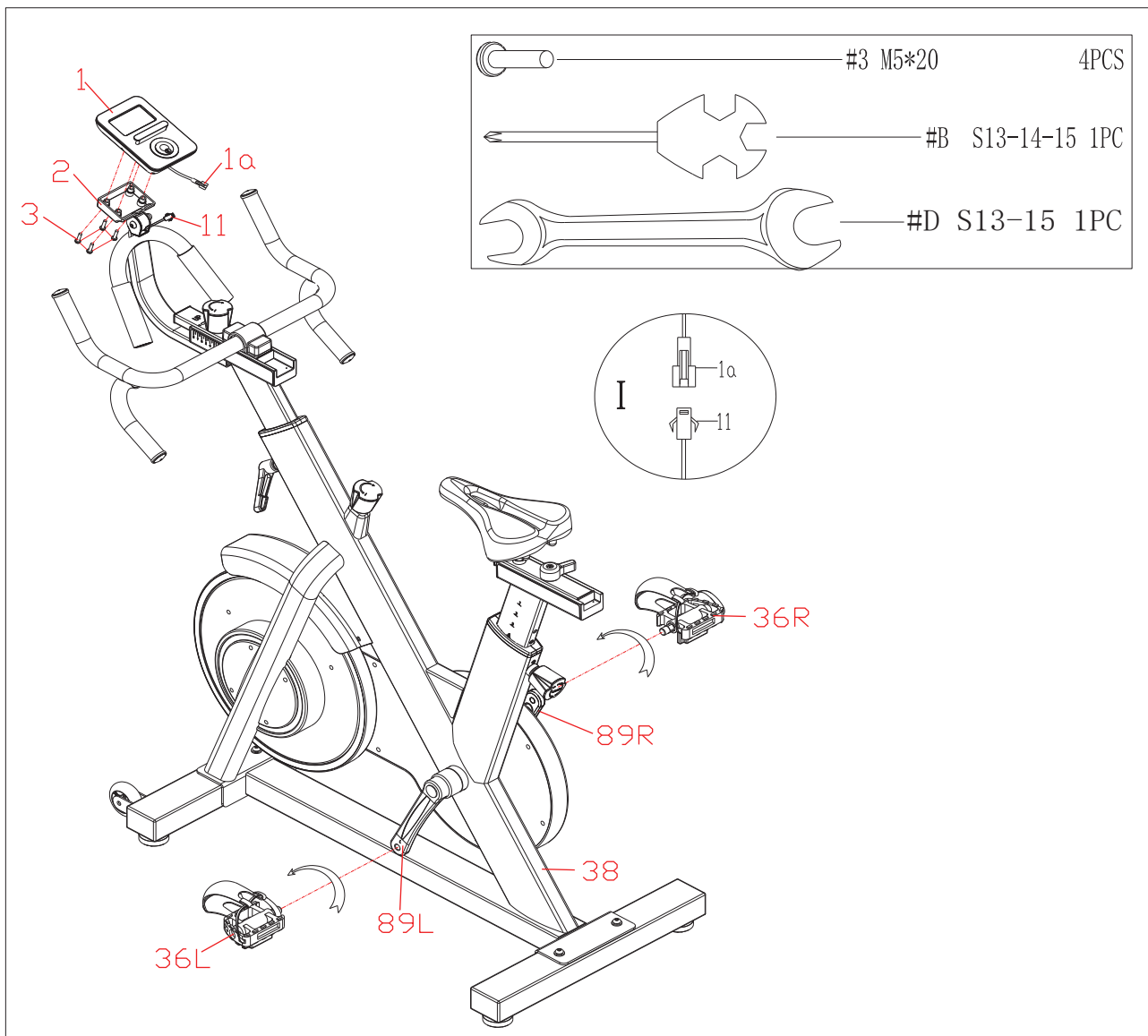

Using the spanner (B), carefully loosen the 4 bolts (3) from the computer (1).

Ensure a secure connection between wire (1a) and trunk wire 1 (11).

Fasten the computer (1) onto the computer holder (2) using 4 bolts (3) and spanner (B).

Securely tighten the pedals (36L/R) into the crank (89L/R) using spanner (B).

ASSEMBLY COMPLETE

Assembly of your **Elite Peltex Spin Bike** is now complete! Be sure to fully inspect your machine before using it for the first time.

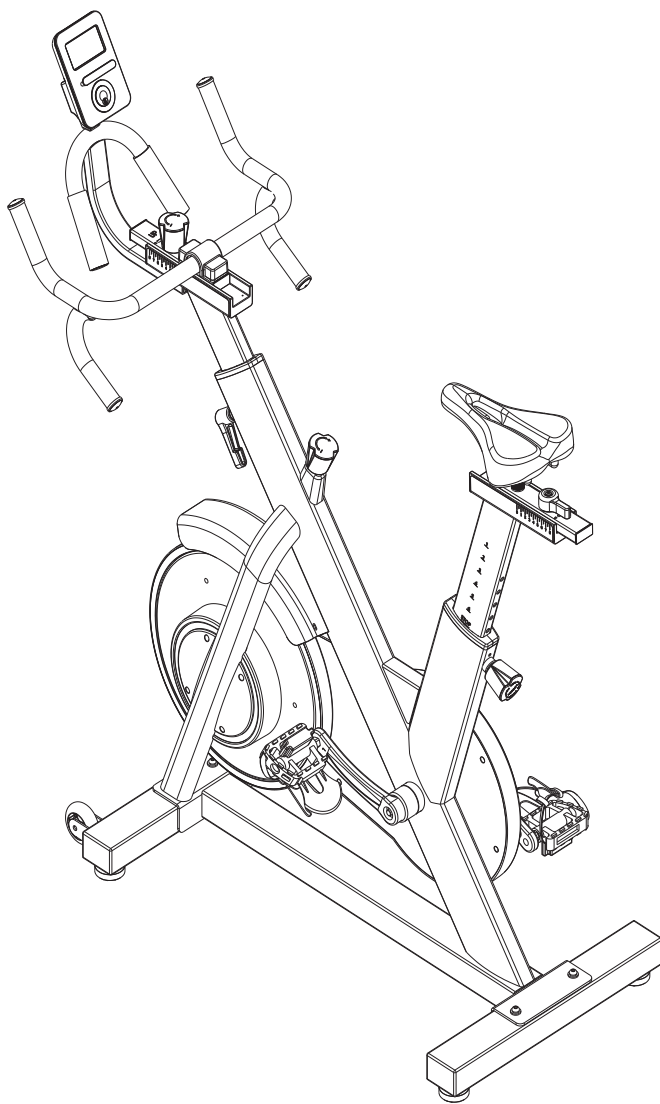

⚠ WARNING

Failure to visually check and test and tech the assembly before use can cause damage to the **Elite Peltex Spin Bike** and serious injury to users and bystanders and can also compromise the effectiveness of your exercise program.

CONSOLE USER INSTRUCTIONS

Functional Button:

- **MODE:** Press to select functions. Hold for 5 seconds to switch between KM/H or Mile/H.

Function and Operations:

- **SCAN:** Press MODE until "SCAN" appears; monitor will cycle through: time, calories, speed, distance, and total distance. Each display will hold for 4 seconds.
- **TIME (TMR):** Records total exercise duration.
- **SPEED (SPD):** Displays current speed.
- **DISTANCE (DST):** Tracks distance covered during exercise.
- **CALORIES (CAL):** Calculates total calories burned.
- **TOTAL DISTANCE (ODO):** Tracks overall distance covered since battery installation.
- **AUTO ON/OFF & AUTO START/STOP:** Automatic Power Off: If idle for 4 minutes without activity, the power shuts off. Monitor Activation: Monitor activates when the wheel is in motion or when buttons are pressed.

Specifications:

FUNCTION	AUTO SCAN	Every 4 seconds
	TIME(TMR)	0:00~99:59 (minutes:seconds)
	CURRENT SPEED(SPD)	The maximum pick-up signal is 999.9KM/H or Mile/H
	TRIP DISTANCE(DST)	0~999.9KM or Miles
	CALORIES(CAL)	0~9999cal
	TOTAL DISTANCE(ODO)	0~999.9KM or Miles
BATTERY TYPE		2PCS of SIZE-AAAor UM-4
OPERATING TEMPERATURE		0°C~+40°C (32°F~104°F)
STORAGE TEMPERATURE		-10°C~+60°C(14°F~168°F)

EXPLODED DIAGRAM

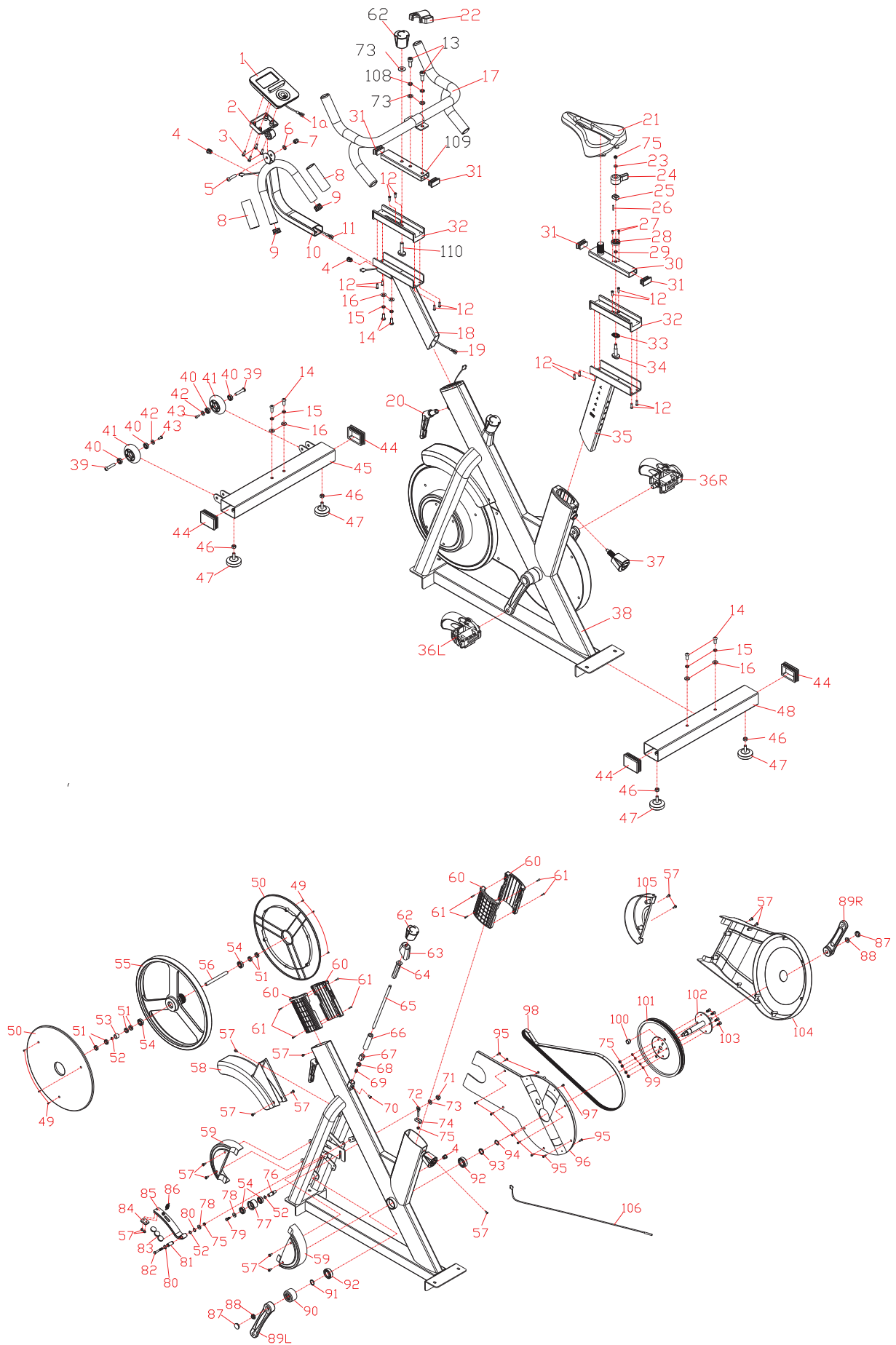

SETTING YOUR SPIN BIKE UP



Saddle Height Adjustment

Having your bike seat adjusted to the right height is essential for a comfortable ride, efficient pedalling and avoiding injury. There are 2 adjustments located on the seat post. The first is a vertical height adjustment, the second is for horizontal seat position. Although there are many methods and opinions on the optimal saddle setting, the following is a quick and easy method to get started. Further adjustments can be made afterwards to optimise your position and comfort.

Saddle Height Adjustment

- Place your heels on the bike pedals and pedal backward. Your legs should be fully extended with your knees straight. If your hips rock from side to side while pedalling backward, the seat is too high.
- Place the ball of your foot on the pedal. There should now be a slight bend in your knee when the pedal is at its lowest point. This is a good starting point.



Adjusting the Seat Fore-and-Aft Position

Adjusting the Seat Fore-and-Aft Position

Once you've adjusted seat height, it's time to find the correct fore-and-aft position of the saddle. This determines where you sit in relationship to the crank set (where the pedals are attached), which helps decide how comfortable and efficient you'll be when riding. This also minimises stress to the knee by being in a more neutral position.

If you want to try to check the fore-and-aft setting at home, you will need a second person and a plumb line (a length of string with a nut or washer tied on the end will work fine).

Whilst sitting on the seat saddle bring your right crank arm around and have your helper stop the crank when the pedal is at three o'clock or parallel with the floor. Note that for this measurement to be accurate, your shoes must be correctly positioned on the pedals (the balls of your feet should be over the pedal axles).

SETTING YOUR SPIN BIKE UP



Holding this position, have your helper place the end of the plumb line (line of string with nut/washer) on the front of your leg, at a point just below the bony protrusion that's beneath the kneecap.

The plumb line's weight should hang over your shoe. Check again to ensure that the crank-arm and pedal are level. By looking at the plumb line the knee should be in alignment with the centre spindle or axle of the pedal. Adjust the saddle to the correct position then tighten the locking pin.

Handle Bar Adjustment

The positioning of the handlebars can be dependent on the bike design and adjustability available.

To minimise back strain, adjust the height to a level that is comfortable for you. We recommend the handlebars be positioned at the same height level as the bike seat as a good starting point.

Please note: *The spin bikes shown in the 'setting up your spin bike' section are for demonstration purposes only and your spin bike may vary in aesthetics and features.*

CARE AND MAINTENANCE

WARNING

Before cleaning or carrying out any maintenance on your spin bike, ensure the power is turned off and the power cord removed from the plug socket.

Prolong the life of your spin bike by performing periodic maintenance checks. Not only does this ensure your machine is in full working order to ensure they continue to run smoothly and reliably, but it will save you service costs in the long run.

- General cleaning of the unit after use will protect the bikes powder-coated framework and prevent unnecessary corrosion stains and damage to the structural components from sweat and perspiration.
- Check all nuts and bolts securing the framework, seat and handlebar assemblies are tight.
- Ensure the pedals are securely attached to the crank arms. When tightening pay attention to the reverse thread (tightening Anti-clockwise) on the left hand pedal assembly, when sitting on the bike. Be careful not to strip or force the pedal thread when tightening.

Friction Brake Pad System

Where a felt-type brake pad system is used, periodically lubricate the pad with a silicone based spray to prolong it's service life. Do NOT use WD40 or similar lubricants. Ensure the contact surface on the flywheel is kept clean and free of debris and sweat.

If a leather material brake pad is used, no lubrication is required.

NOTE: DO NOT ATTEMPT TO OVERTIGHTEN THE TENSION DIAL ADJUSTMENT, OVER TIGHTENING MAY CAUSE DAMAGE TO THE SHAFT THREAD.

Magnetic Braking System

If you have a magnetic spin cycle, there is normally no adjustment necessary as they use a low maintenance non-friction resistance system. Periodically check the movement of the magnetic brake via the cable level or tension dial to ensure it does not come into contact with the rotating flywheel at any time. The flywheel surface should be kept clean and free of dust debris and sweat.

Chain Driven

The chain will require periodic lubrication of the chain to maintain a smooth and quiet motion. The chain guard may need to be removed to perform this procedure. You may wish to put a drop sheet or similar under your bike to protect your floor coverings.

Before lubricating the chain, use an old rag to remove any old oil or residue from the chain. Lightly apply a chain or multipurpose oil to the chain. Secure the chain guard before using your bike.

Belt Driven

Belts do not require lubrication, however through normal wear and tear they may stretch and require forward adjustment of the flywheel to increase the belt tension if any slippage occurs. The adjustable tension bolts are normally found attached to the flywheel axle. DO NOT over-tighten, only enough to stop any slipping of the belt drive system.

If you require further assistance or advice contact the Elite Fitness Service Department or your nearest Elite Fitness Store.

LIMITED WARRANTY

Warranty Range

Damage in correct maintenance and normal operations (not factitious factors). Warranty card to the original purchaser, shall not be transferred.

Warranty Time

HOME USE

- 10 Year Frame
- 1 Year Parts and Labour

The following conditions are not under warranty range:

- A) As a result of abuse, neglect, accident, or unauthorized modification;
- B) The damage due to incorrect assembly or adjustment of the machine;

The Spin bike should not be:

- A) Plugged into a multi-board plug device. The spin bike requires a dedicated power circuit and should be plugged directly into the wall socket.
- B) Used with an extension cord any longer than 1.5m.

Repair and Maintenance Service

Please contact our Elite Fitness Service Department at eliteservice@elitefitness.co.nz or visit www.elitefitness.co.nz for any service related issues or advice on preventative maintenance servicing procedures.

WARM-UP EXERCISE

Warm up exercise is important in preparing the muscles for activity whilst minimising the risk of injury. You may choose to warm up with a light/brisk walking pace for 5-10 minutes before stopping and performing some simple stretches. (As shown in the pictures below)

- Hamstring Stretch (Standing) Keep your knees slightly bent and slowly lean forward, back and shoulders relaxed, reaching towards your toes. You should feel the tension and slight discomfort in your hamstring muscles. Hold for 15-20 seconds. Repeat 2-3 times.
- Hamstrings Stretches (Seated) Sitting on the floor preferably on a mat, put one leg straight, the other inward and close to the inside of the straight leg. Lean forward from the hips, reaching towards your toes. Hold for 10-15 seconds, and relax. Repeat 3 times for each leg (See picture 2).
- Crus and Feet Tendon Stretches Standing with two hands on the wall or tree, one leg behind. Keeping your legs straight and the heel on the ground, lean forward towards the wall or tree. Hold for 10-15 seconds, and relax. Repeat 3 times for each leg (See picture 3).
- Quadriceps Stretches Keeping your balance with your left hand holding onto a wall or stationery fixture, grasp your right foot with your right hand and stretch your right heel toward your buttocks slowly, until you feel the stretch in the front of your thigh. Hold for 10-15 seconds, and relax. Repeat 3 times for each leg (See picture 4).
- Sartorius (Inner Muscles of the Thigh) Muscle
- Stretches Sitting down with the soles of your feet or shoes together and your knees positioned outward. Pull your feet towards your groin until you can feel the stretch. Hold for 10-15 seconds, and relax. Repeat 3 times (See picture 5).

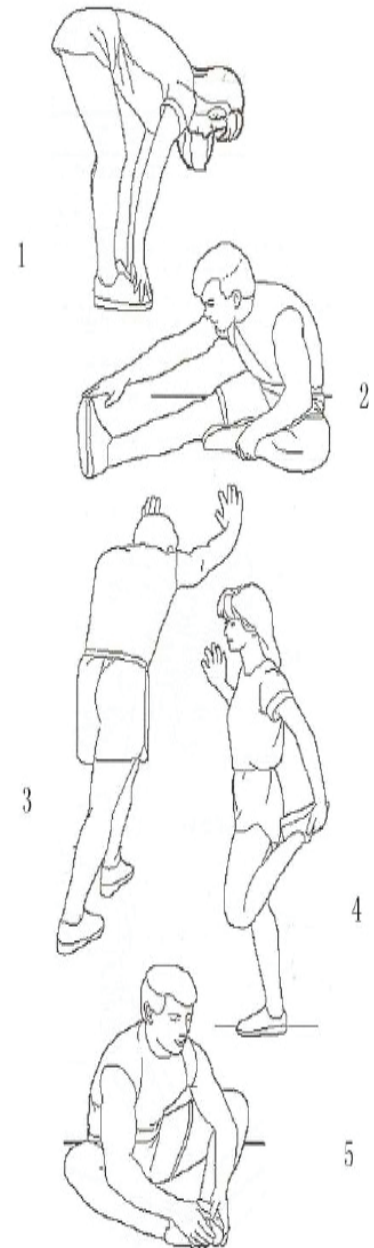

TRAINING STAGES

		Exercise Zone									
		AGE									
Beats Per Minute	100%	200	195	190	185	180	175	170	165	155	150
		VO2 Max (Maximum Effort)									
	90%	180	176	171	167	162	158	153	149	140	135
		Anaerobic (Hardcore Training)									
	80%	160	156	152	148	144	140	136	132	124	120
		Aerobic (Cardio Training/Endurance)									
	70%	140	137	133	130	126	123	119	116	109	105
	Weight Control (Fitness/Fat Burn)										
60%	120	117	114	111	108	105	102	99	93	90	
	Moderate Activity (Maintenance/Warm up)										
50%	100	98	95	93	90	88	85	83	78	75	

Cardiovascular training plays an important part in maintaining a healthy heart and lung function, so it's no surprise we should be paying attention to how quickly our heart beats during exercise. The chart above outlines a range of heart rate training zones determined by the individual's age and workout goals to ensure you train safely and effectively.

Heart Rate can be measured by using the radial (wrist) or carotid (neck) pulse using your index and middle fingers, counting the beats for 10 seconds and multiplying by 6. Alternatively, the use of a Wireless Telemetry Heart Rate strap and watch will give you an accurate Beats Per Minute (BPM) reading.

$220 - \text{AGE} = \text{TMHR}$ (Theoretical Maximum Heart Rate)

$\text{TMHR} \times 85\% =$ (Upper Training Limit) bpm (Beats per Minute)

$\text{TMHR} \times 65\% =$ (Lower Training Limit) bpm

Note: Contact heart rate may provide inaccurate readings and is designed only as a guide

Example: $220 - 39 = 181$ bpm

$181 \times 85\% (0.85) = 154$ bpm (Upper Training Limit)

$181 \times 65\% (0.65) = 118$ bpm (Lower Training Limit)



For more information about our Elite exercise equipment or other brands that we stock for your home, visit www.elitefitness.co.nz

Copyright © 2024 Elite Fitness

Elite Fitness, 28 Morrin Road, St. Johns, Auckland, New Zealand
0800 243 834, www.elitefitness.co.nz

Keep up to date with the latest products, competitions and equipment, follow us on our social media sites.



[@EliteFitnessNZ](https://www.instagram.com/EliteFitnessNZ)

[@EliteFitnessTV](https://www.youtube.com/EliteFitnessTV)