

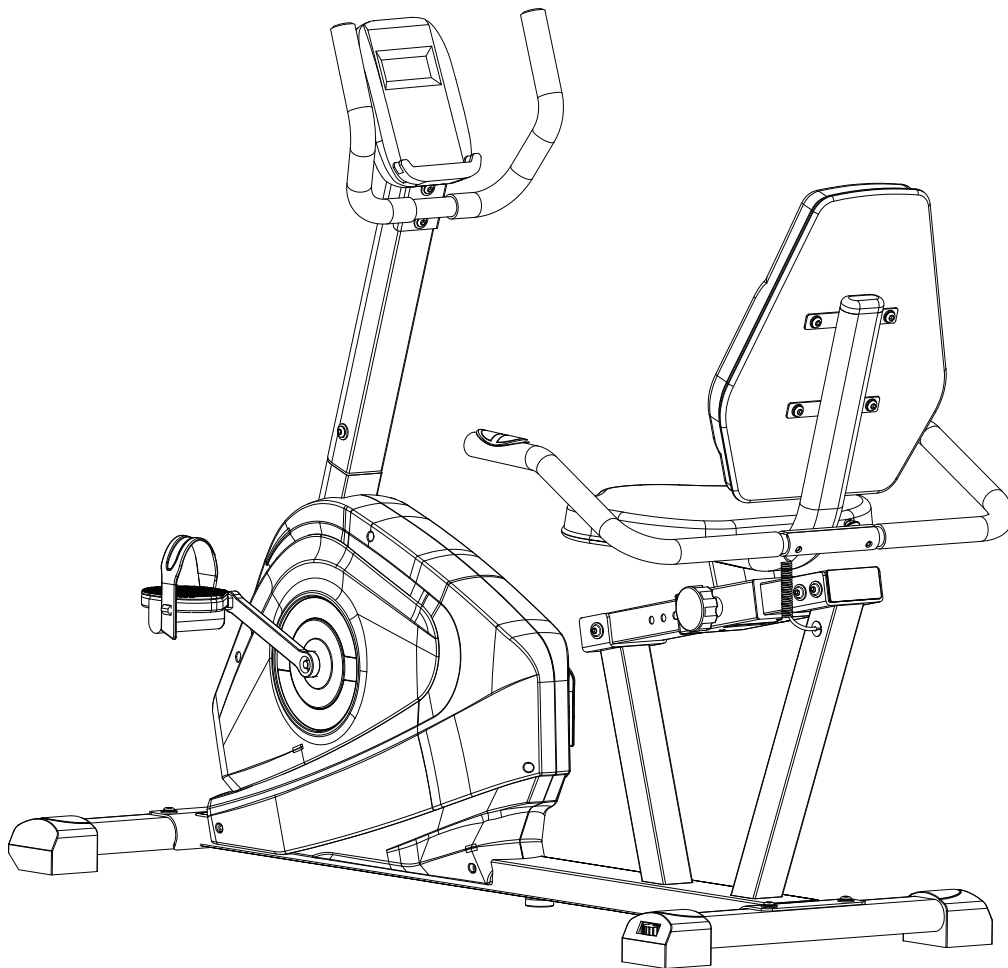

ASSEMBLY MANUAL >

DELTA SL

RECUMBENT BIKE



Record serial number

Elite DELTA SL Recumbent Bike

Thank you for purchasing the **Elite Delta SL Recumbent Bike**.

For over 30 years, Elite Fitness™ has been New Zealand's largest supplier of fitness equipment. Our aim and vision is to provide you Elite™ branded products, tested to the highest standard for quality and biomechanics at the best possible price.

Please read through this manual to familiarise yourself with the operation of your new **Elite Delta SL**. Doing so will help to ensure that you get the most out of your machine, enjoying safe and effective workouts ahead.

Even though we go to great efforts to ensure the quality of each product we produce, occasional errors and or omissions do occur. In any event should you find this product to have either a defective or a missing part, please contact us for a replacement.

SERVICE & WARRANTY

For service and warranty assistance please visit:

www.elitefitness.co.nz/service

Online forms are available for Service, Warranty and Parts requests.

(09) 258 9067

Elite Fitness HQ

28 Morrin Road

St Johns

Auckland, New Zealand

info@elitefitness.co.nz

0800 2 438 348

CONTENTS

Important Safety Instructions	3	Care and Maintenance	21
Product Specifications	4	Maintenance Log	22
Parts List	5	Limited Warranty	23
Assembly Instructions	7	Warm-Up Exercise	24
Exploded Drawing	15	Training Stages	25
Display Console	17	Notes	26
Setting Your Bike Up	19		

IMPORTANT SAFETY INSTRUCTIONS

The following definition applied to the word “WARNING” when used in this manual:



WARNING

Used to call attention to POTENTIAL hazards that could result in personal injury.

READ ALL INSTRUCTIONS BEFORE USING THE MACHINE

This product has been designed for **home use only**. Product liability and warranty conditions will not be applicable to products being subjected to professional use or products being used in a commercial environment. e.g Gym Centre, Retirement Centre, Home Based PT Studio and Physio.

This exercise machine is built for optimum safety. However, certain precautions apply whenever you operate a piece of exercise equipment. Be sure to read the entire manual before you assemble or operate your machine. In particular, note the following safety precautions.

- Read all instructions in this manual before using this equipment.
- Use the machine only for its intended use as described in this Manual.
- Inspect and tighten all the loose parts before this equipment is used.
- Keep hands away from moving parts.
- Keep children and pets away from the machine at all times. **DO NOT** leave children unattended in the same room with the machine.
- Before using the machine to exercise, always do stretching exercises to properly warm up.
- Inspect the machine before each use; make sure all of the connections are tightly secured.
- Only one person at a time should use the machine.
- If the user experiences dizziness, nausea, chest pain, or any other abnormal symptoms, **STOP** the workout at once. **CONSULT A PHYSICIAN IMMEDIATELY.**
- Position the machine on a clear, levelled surface. **DO NOT** use the machine near water or outdoors.
- Always wear appropriate workout clothing when exercising. **DO NOT** wear robes or other clothing that could become caught in the machine. Sporting shoes are recommended when using the machine.
- Do not place any sharp object around the machine.
- Disabled persons should not use the machine without a qualified person or physician in attendance.
- Never operate the machine if the machine is not functioning properly.
- Only carry out training work on the equipment when it is in perfect working order. Only use original spare parts in the event of a repair.
- Do not use strong solvents for cleaning, and only use the tools supplied, or suitable ones of your own, for any repairs that may be required. Please dispose of the packaging and any parts that have to be replaced subsequently (all parts for the unit) at suitable collecting points or containers with a view to saving the environment.
- **DO NOT** extend the seat stem past the warning line “Max” when adjusting the seat height.
- Not for therapeutic use.

WARNING: Before beginning any exercise programme, consult your physician. This is especially important for persons with pre-existing health problems. The seller assumes no responsibility for personal injury or property damage sustained by or through the use of this product.

SERVICE HINTS: The high quality standard of this product only will be kept if you, on a regular basis, check all screw connections and moving parts on proper fitting. Damaged parts need to be changed immediately. During the time of repair the product must not be used by anybody.

IMPORTANT HINTS:

- A) This product has been tested in accordance with the requirements of EN 957-1/A1, EN 957-5, standard, Class HA (HOME USE). The maximum load is limited to 120 KGS.
- B) Parents should be aware of the risk factor of young children playing on fitness equipment unattended. Make sure that children are instructed properly in the use of the product and in the controlled execution of the different exercises. Misuse of the product could result in serious injury.

PRODUCT SPECIFICATIONS

User Weight Capacity:	120 kg
-----------------------	--------

Shipping Weight:	36 kg
------------------	-------

Net Weight:	32.5 kg
-------------	---------

PARTS LIST

NO.	NAME	SPECIFICATION	QTY	NO.	NAME	SPECIFICATION	QTY
1	Main frame		1	42	Magnet board		1
2	Front stabiliser		1	43	Tension spring	∅ 1.0×∅ 15×55L	1
3	Rear stabiliser		1	44	Axle of rotation	∅ 12×67	1
4	saddle adjusting tube		1	45	Circlip	∅ 10	2
5	Saddle		1	46	Screw	M6×20L	2
6	Back cushion		1	47	Flywheel axle	∅ 20×107L	1
7	Front post		1	48	Bearing seat	ABS	2
8	Front handle bar		1	49	Bearing	6001ZZ	2
9	Console		1	50	Bearing end cover piece		2
10	Knob		1	51	Screw	M6×10L	8
11L	Pedal-L	1/2"-20-L	1	52	Flat washer	∅ 6×∅ 13×1.5t	2
11R	Pedal-R	1/2"-20-R	1	53	Screw	ST4.2×19H	8
12	Front stabilizer tube plug-left	PT40×80	1	54	Screw	M8×50H	4
13	Front stabilizer tube plug-right	PT40×80	1	55	Flat washer	∅ 8.5×∅ 20×1.5t	22
14	Console wire -top		1	56	Cap nut	M8×1.25	2
15	Console wire-bottom		1	57	Saddle support set		1
16	Pulse sensor wire-middle		1	58	Screw	M8×45	2
17	Pulse sensor wire-top		1	59	Protective plug	∅ 22×∅ 12.2×12.5L	1
18	Screw	M5	4	60	Power wire		1
19	Pulse sensor wire		1	61	Motor wire		1
20	Pulse sensor		1	62	Handle bar tube plug		4
21	Motor		1	63	Screw	M8×16H	20
22	Tube bushing	40×80-50×100	2	64	Rectangular tube plug	40×80	2
23	Flywheel	∅ 240×40	1	65	Screw	ST4.2×16H	9
24	Cover-left	ABS	1	66	Curved washer	∅ 8.2×∅ 20×1.5t	6
25	Cover-right	ABS	1	67	Rear handle bar		1
26	Pulley Axle welding Group		1	68	Screw	M5×15H	4
27	Belt pulley	∅ 240×20×PJ6	1	69	Circlip		1
28	Adjusting pad	∅ 48×16L	1	70	Wave washer		1
29	Decorative circle	ABS	4	71	Bearing		2
30	Rear stabilizer tube plug	PT40×80	2	72	Pulley Axle Spacer Bush		1
31	Crank decorative cove	PVC	2	73	Hexagonal cylindrical head screw set	M6×12	4
32	Nylon nut	M10×1.5	2	74	Left crank		1
33	Belt	PJ6 - 390	1	75	Right crank		1
34	Tension spring	∅ 2.5×∅	1	76	Screw	M6×35L	1

PARTS LIST

35	Pinch roller fixing plate		1	77	Front handle bar foam		2
36	Hex nut	M6	1	78	Rear handle bar foam		2
37	Fixing plate screw	M10×1.5×42L	1	79	Oval tube plug	PT30×60	2
38	Pinch roller	∅ 37×∅ 30×22.4L	1	80	Adapter		1
39	Idler Shaft Bushing	∅ 14×∅ 10.2×6L	1	81	Flywheel retainer		2
40	Flat washer	∅ 10.2×∅ 20×1.5t	2	82	Screw		6
41	Fixing plate screw	M10×1.5×20L	1	83	Trim Cover		6

HARDWARE PACKAGE

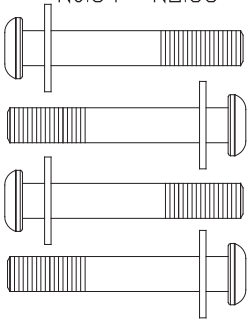
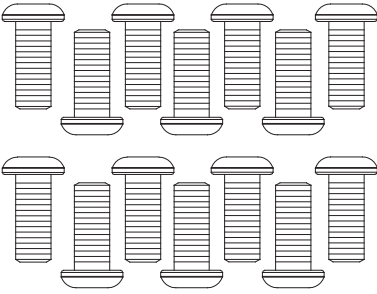
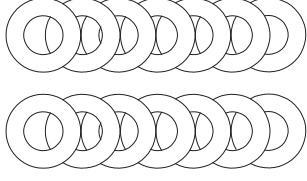
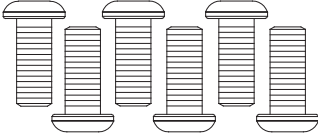
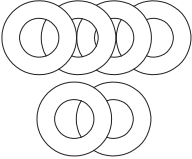
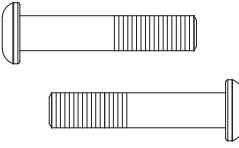
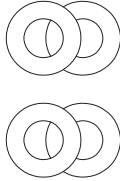
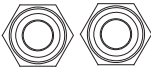
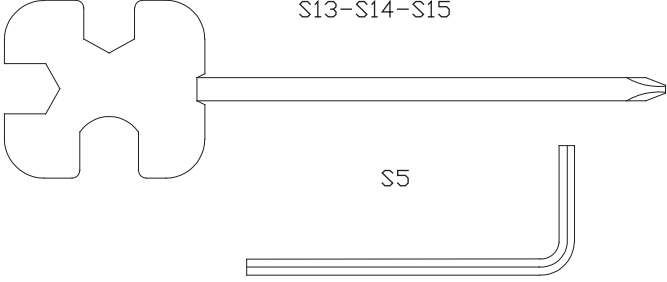
<p>STEP 1</p> <p>N0.54 N0.55</p> 	<p>STEP 3/4</p> <p>N0.63</p>  <p>N0.55</p> 	
<p>STEP 6/7</p> <p>N0.63</p>  <p>N0.55 N0.66</p> 	<p>STEP 5</p> <p>N0.58</p>  <p>N0.66</p>  <p>N0.56</p> 	
<p>S13-S14-S15</p>  <p>S5</p>		

ASSEMBLY INSTRUCTIONS

STEP 1

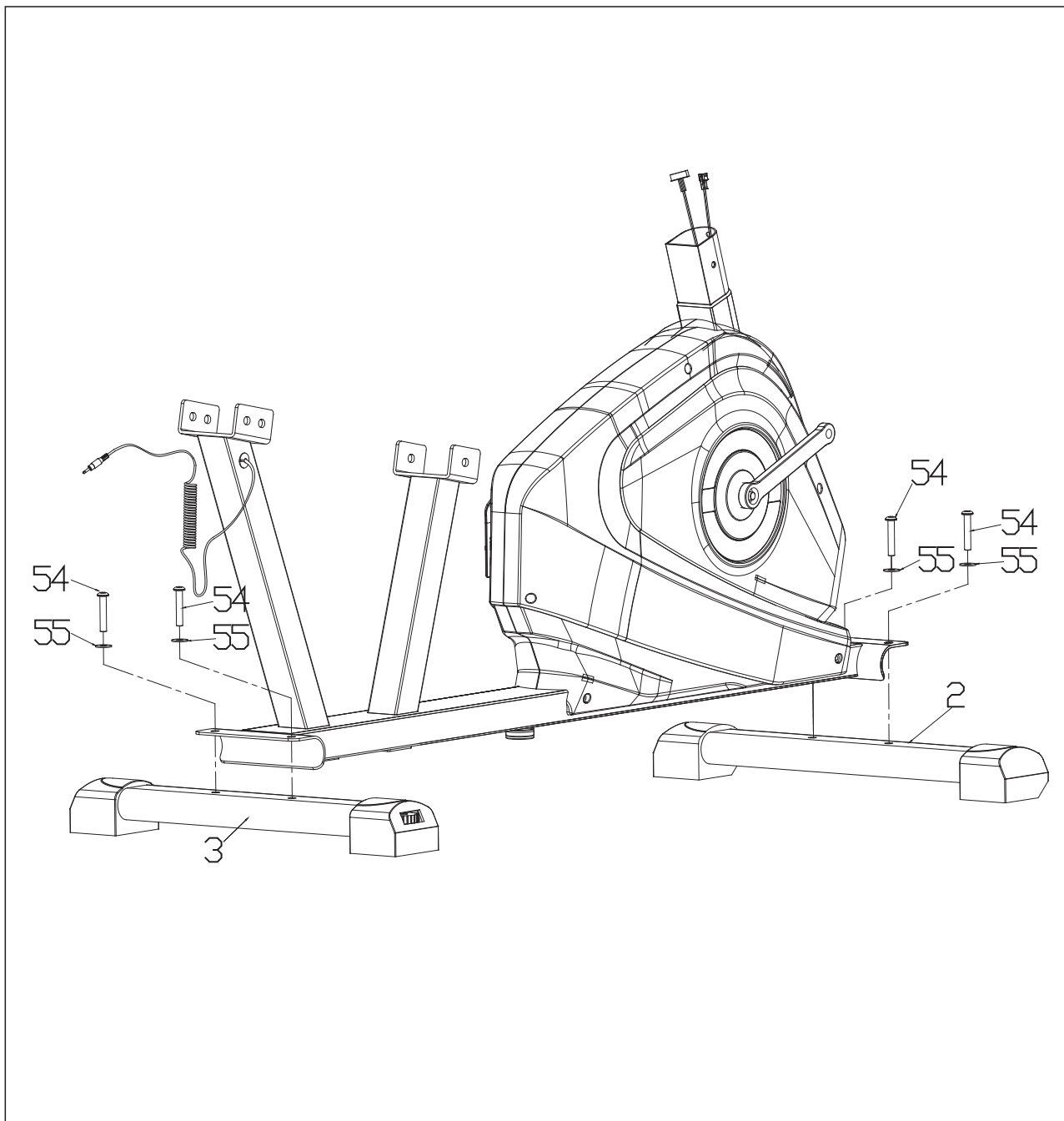

Remove all the screws (54) and flat washers (55) from the front stabiliser (2) and the rear stabiliser (3) using the Allen key, and store them securely.

Attach the front stabiliser (2), which has a transport wheel, to the main frame (1) and tighten it securely with the wrench using the retained hardware. Then, attach and secure the rear stabiliser (3) to the main frame (1) in the same manner.

ASSEMBLY INSTRUCTIONS

STEP 2

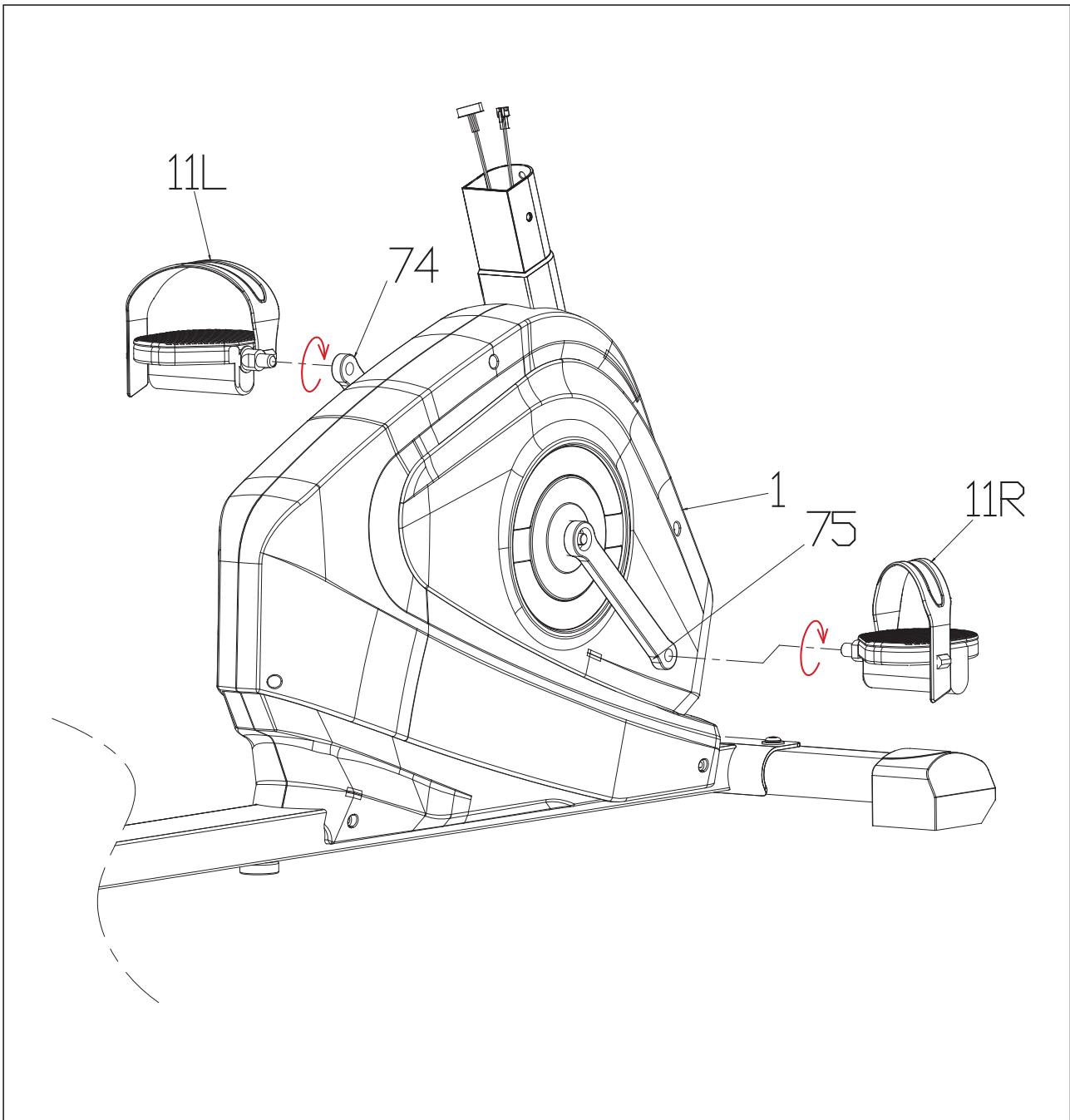

Securely attach the left pedal (11L), indicated with "L," to the left side of the crank (74), also marked with "L," using a spanner in an anticlockwise direction.

Then, fasten the right pedal (11R), labelled "R" onto the right side of the crank (75), marked with "R," using a spanner in a clockwise direction.

ASSEMBLY INSTRUCTIONS

STEP 3

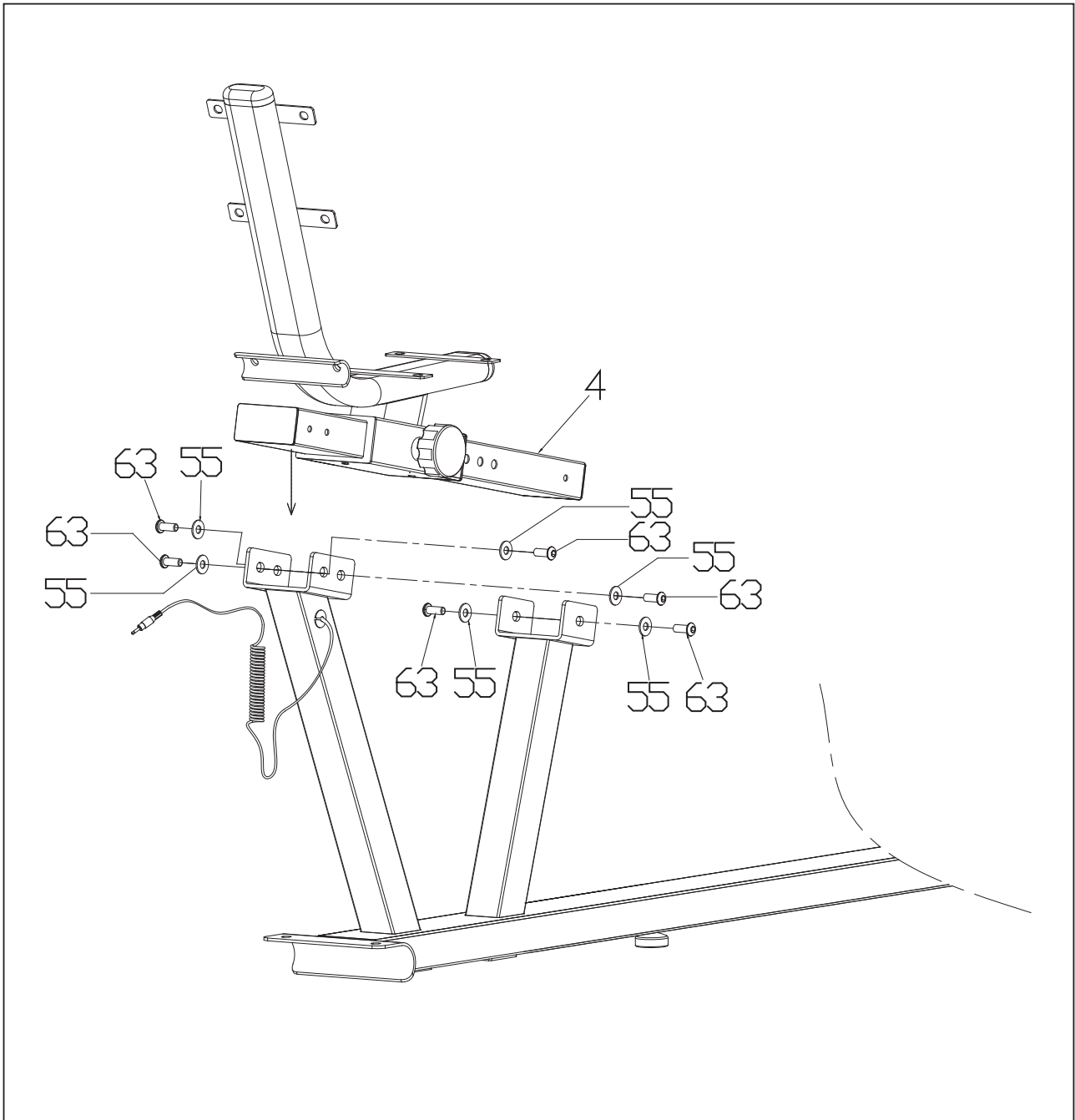

Loosen all the screws (63) and flat washers (55) on the saddle adjusting tube (4) using the wrench, and ensure they are safely stored.

Secure the saddle adjusting tube (4) onto the main frame (1) using the screws (63) and flat washers.

ASSEMBLY INSTRUCTIONS

STEP 4

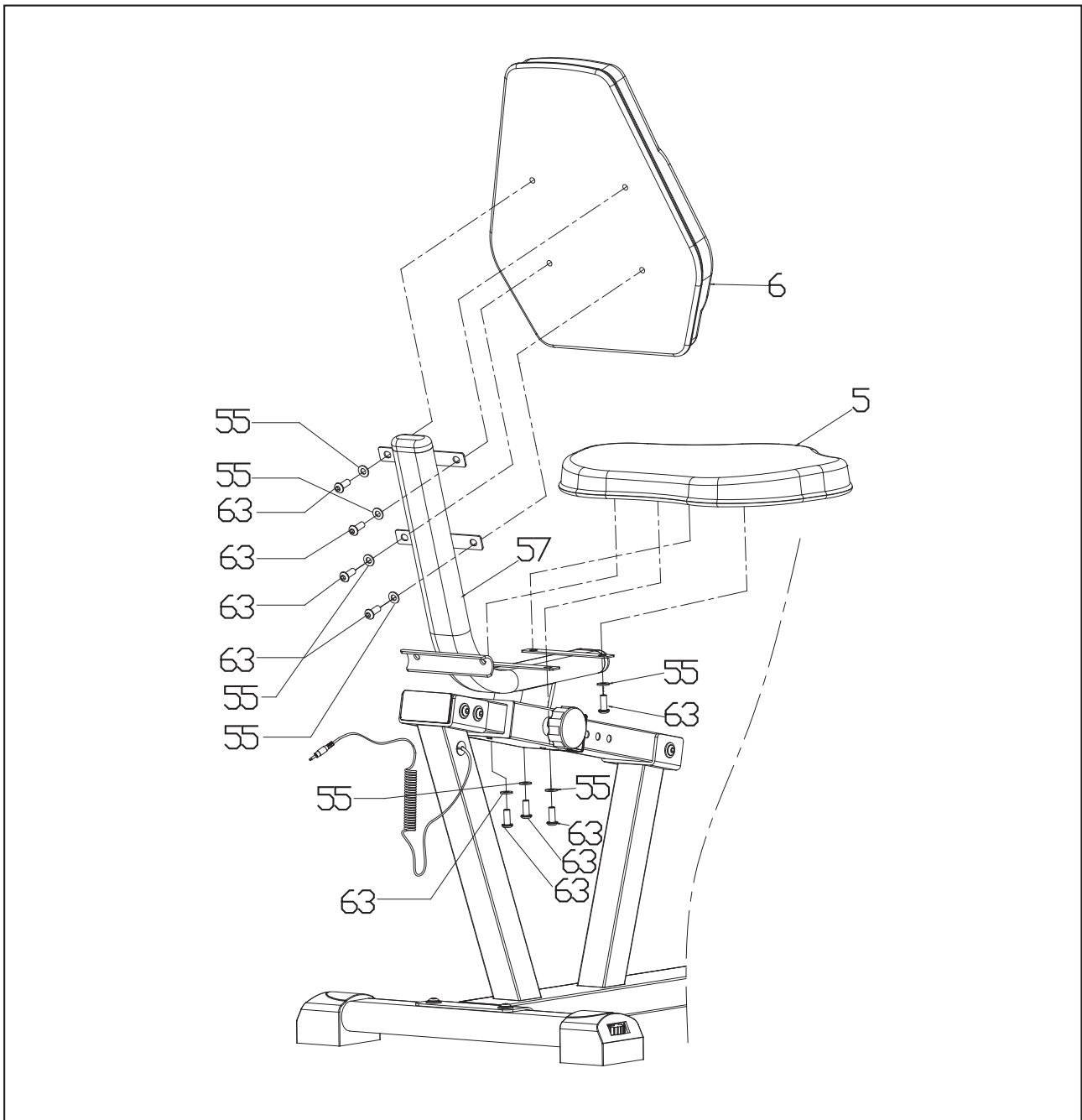

Attach the saddle (5) and back cushion (6) to the saddle support set (57) using screws (63) and flat washers (55), as indicated separately, and securely tighten them with a wrench.

ASSEMBLY INSTRUCTIONS

STEP 5

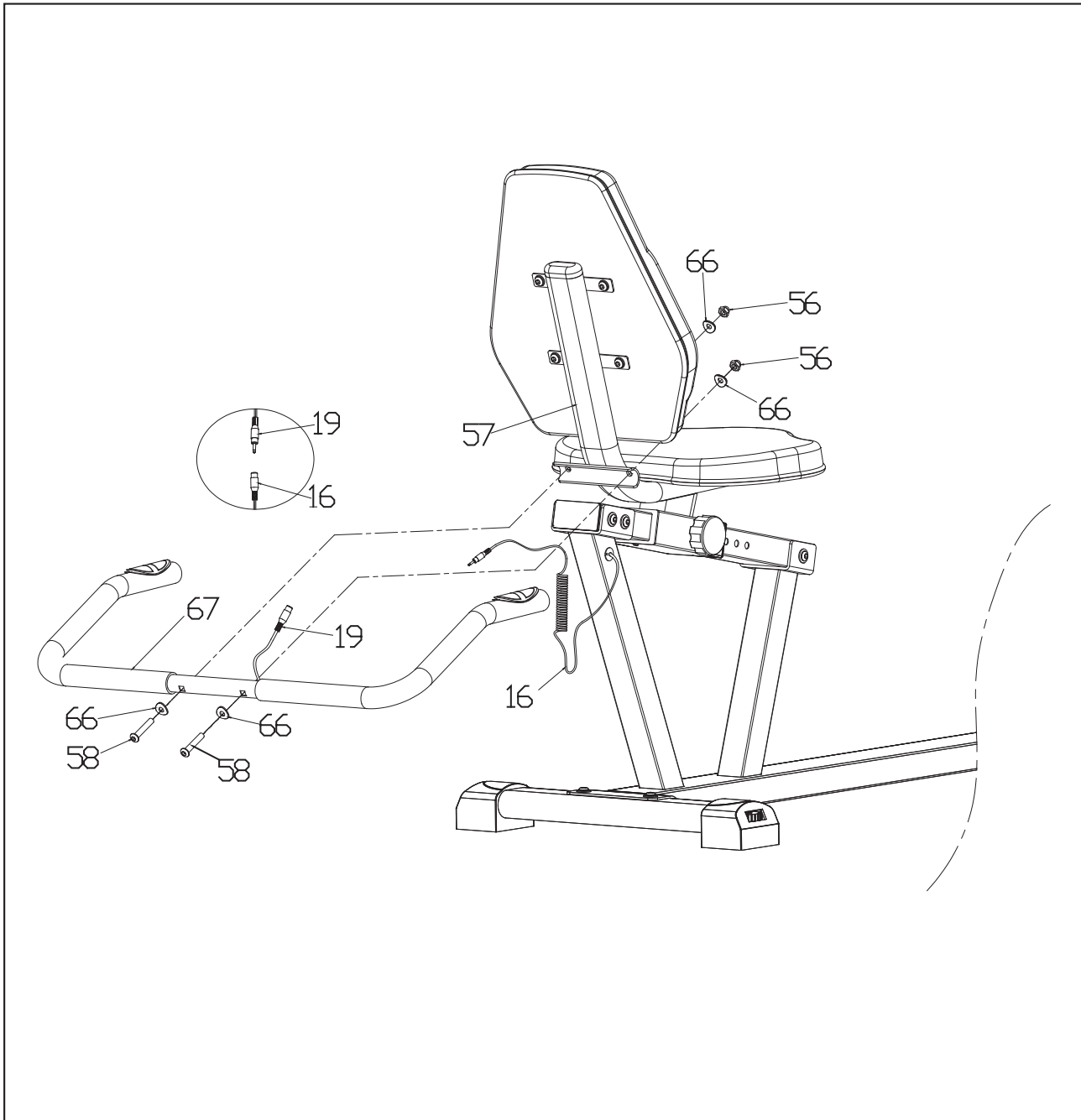
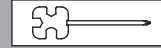

Securely attach the rear handlebar (67) to the saddle support set (57) using the screw (58), curved washer (66), and cap nut (56), and tighten them with a wrench.

Next, ensure the pulse sensor wires (16&19) are correctly connected together.

ASSEMBLY INSTRUCTIONS

STEP 6

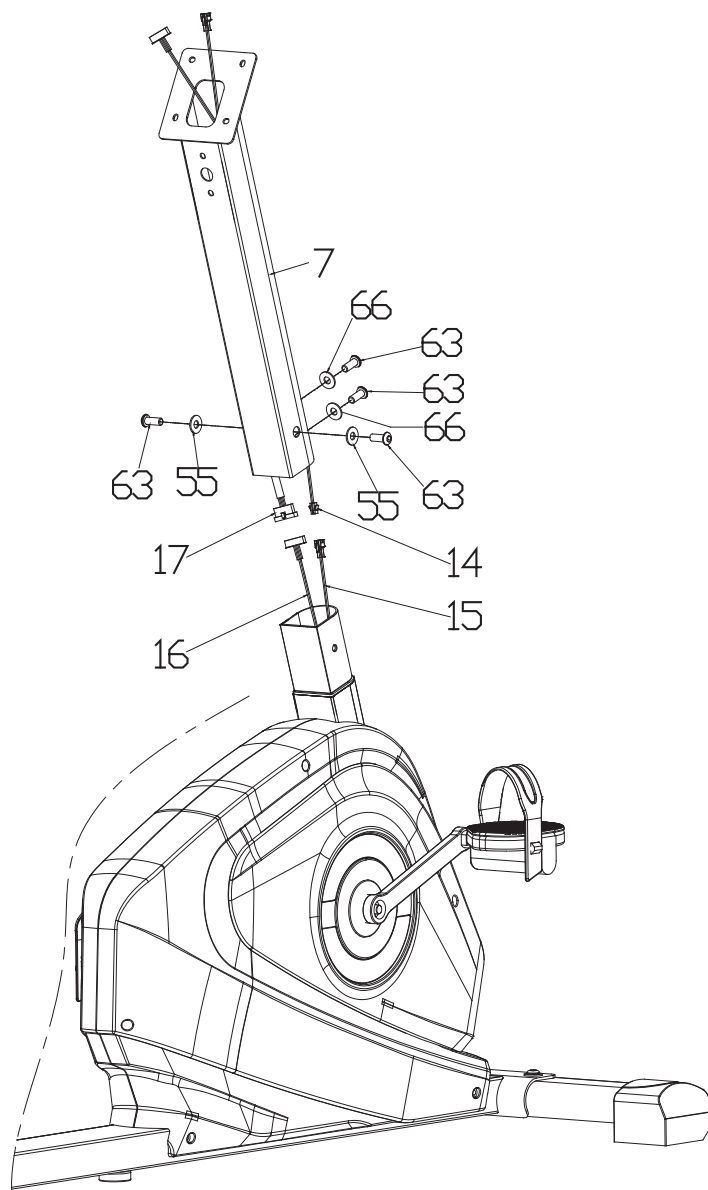

Carefully connect the console wires (14&15) together. Ensure the sensor wires (16&17) are connected correctly. Straighten all pins before connecting wires 14 & 15 and 16 & 17 to prevent console malfunction.

Then, place the front post (7) onto the main frame (1) as illustrated and securely tighten it with the screw (63), flat washer (55), and curved washer (66) using a wrench.

ASSEMBLY INSTRUCTIONS

STEP 7

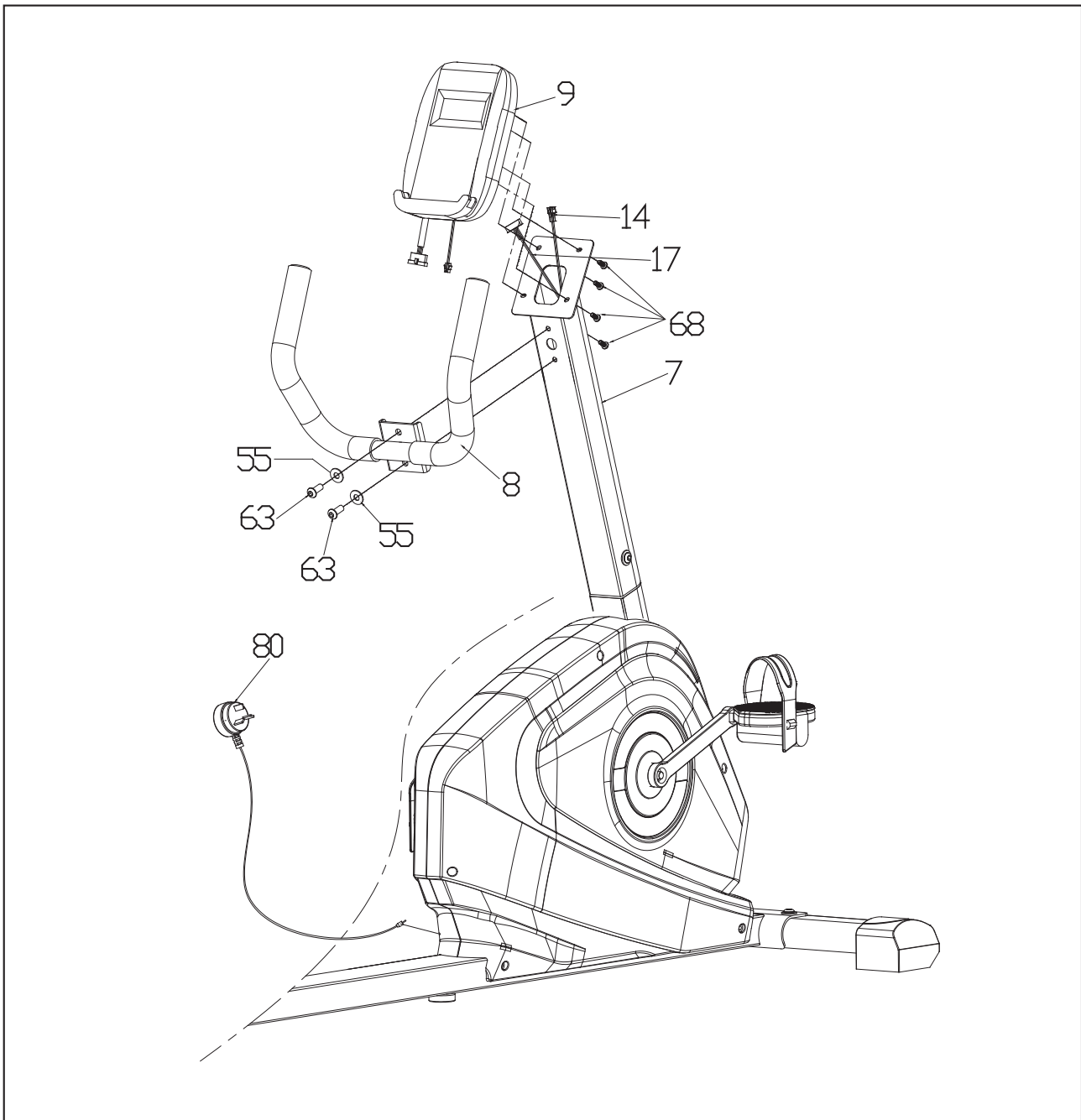
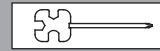

Attach the handlebar (8) to the front post (7) securely using a flat washer (55) and screw (63), ensuring a tight fit.

Connect the console wire (14) and pulse sensor wire (17) together with the wire on the console (9) correctly. Verify that all pins are straight before connecting.

Securely fasten the console (9) onto the plate of the front post (7) using the screws (68).

To use the exercise bike, insert the power adapter (80) into the power socket.

ASSEMBLY INSTRUCTIONS

CONGRATULATIONS

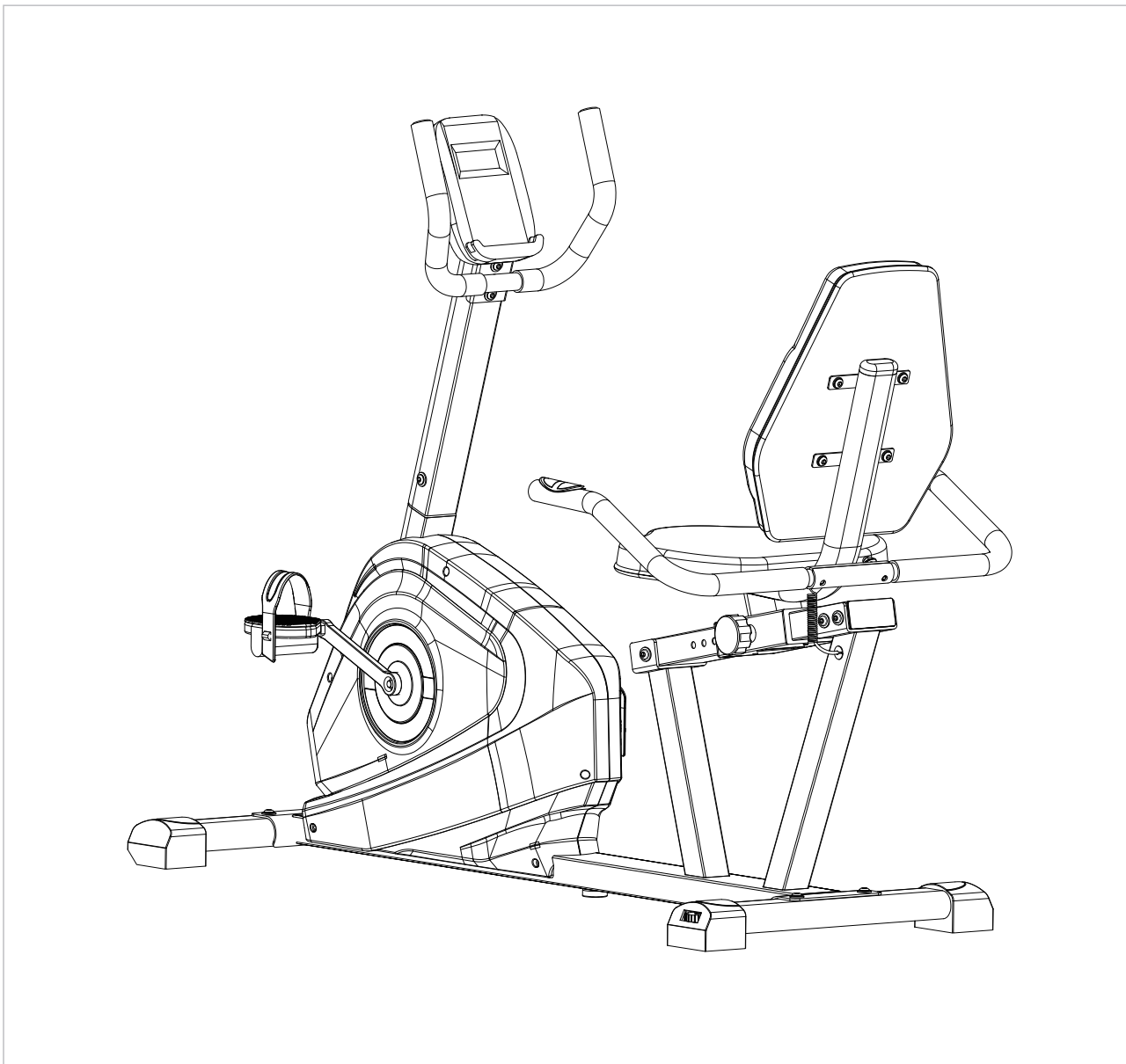

Assembly of your **Elite Delta SL Recumbent Bike** is now complete! Be sure to fully inspect your machine before using it for the first time.

! WARNING

Failure to visually check and test the assembly of your exercycle before use can cause damage to the exercycle, serious injury to users and bystanders and can also compromise the effectiveness of you exercise program.

EXPLODED DRAWING

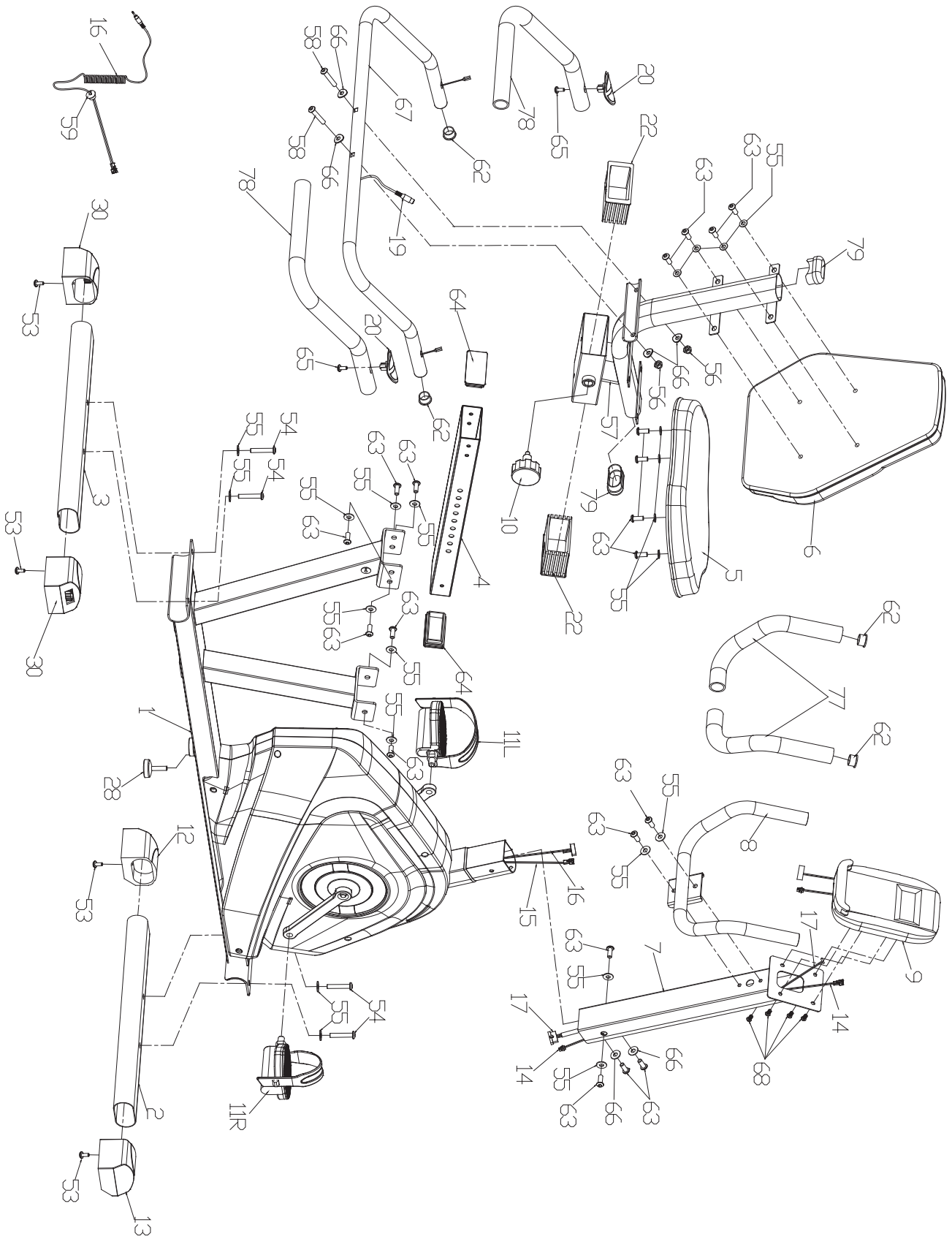

EXPLODED DRAWING

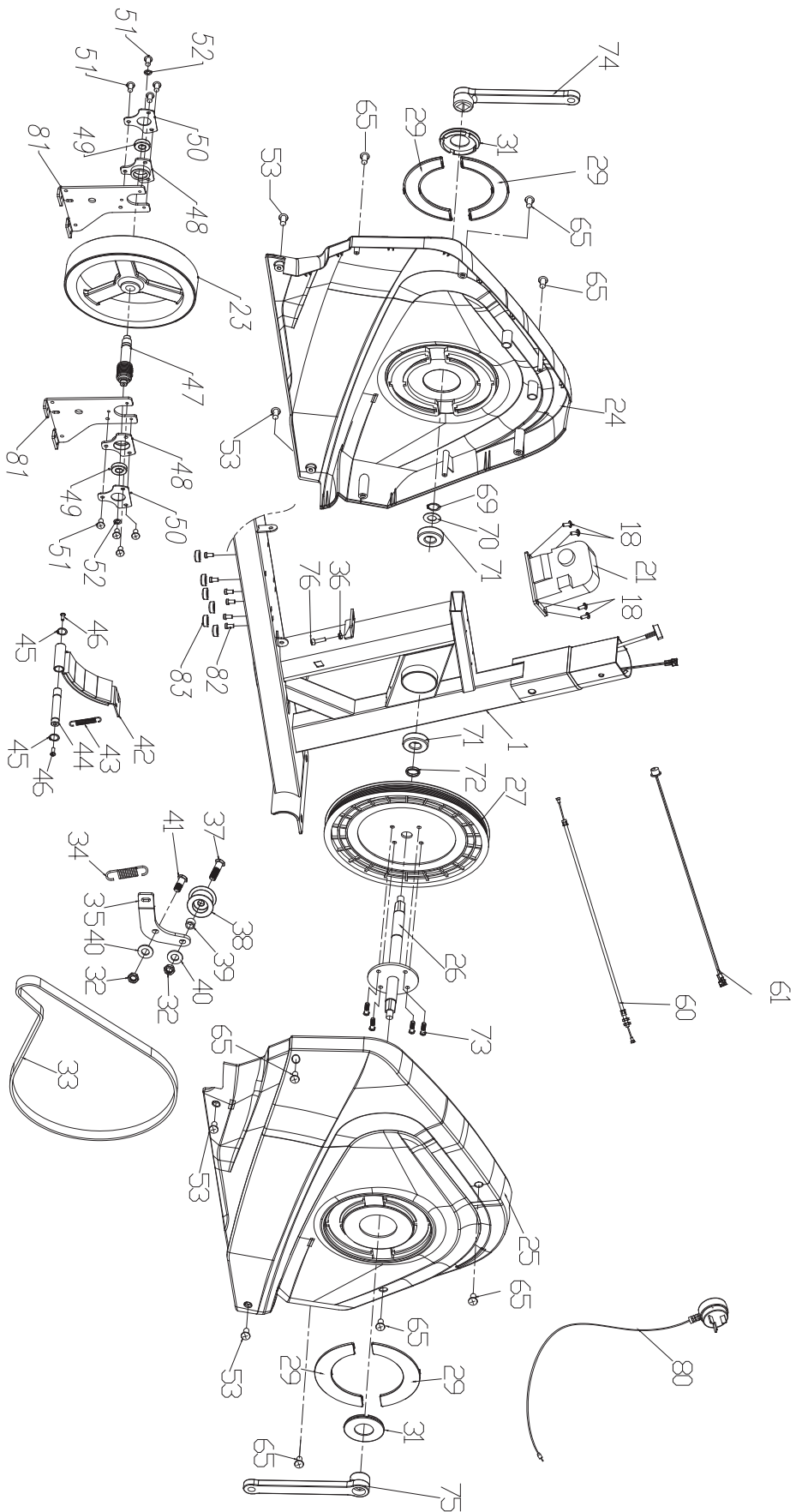

DISPLAY CONSOLE

Functional Buttons:

START/STOP: Initiates and pauses workouts. Begins body fat measurement. Only operates in stop mode. Holding the key for 3 seconds resets all function values to zero.

DOWN: Decreases the value of the selected workout parameter: TIME, DISTANCE, etc. During the workout, it reduces the resistance load.

UP: Increases the value of the selected workout parameter. During the workout, it elevates the resistance load.

ENTER: Used to input desired values or select workout modes.

TEST (PULSE, RECOVERY): Press to enter the Recovery function when the computer has the heart rate value. Recovery indicates Fitness Levels 1-6 after 1 minute. F1 represents the best level, while F6 is the least desirable.

MODE: Press to switch display from RPM to SPEED, ODO to DIST, WATT to Calories during the workout.

Workout Selection: After powering up, use the UP or DOWN keys to select the desired mode, then press ENTER to confirm.

Setting Workout Parameters: After selecting your desired program, you may preset several workout parameters for desired results.

WORKOUT PARAMETERS: TIME / DISTANCE / CALORIES / AGE

Note: Some parameters are not adjustable in certain programs.

Once a program is selected, press ENTER. "Time" parameter will flash. Use the UP or DOWN keys to select the desired time value. Press ENTER to input the value. The flashing prompt will move to the next parameter. Continue using the UP or DOWN keys. Press START/STOP to begin the workout.

Program Operations:

Manual (P1): Select "Manual" using the UP or DOWN key, then press ENTER. The "Time" parameter will flash, allowing adjustment using the UP or DOWN key. Press ENTER to save the value and move to the next parameter to be adjusted. Continue through all desired parameters, then press START/STOP to start the workout.

Pre-programs (P2-P9): There are 8 pre-programmed profiles available, each with 24 levels of resistance. Setting parameters for pre-programs involves selecting a program using the UP or DOWN key, then pressing ENTER. Follow the same process as in the Manual program to adjust parameters.

DISPLAY CONSOLE

Watt Control Program (P10): Select "Watt Control Program" using the UP or DOWN key, then press ENTER. Follow the same parameter setting process as in the Manual program. The computer will automatically adjust the resistance load based on speed to maintain a constant watt value. During the workout, the user can adjust the watt value using the UP or DOWN keys.

BODY FAT PROGRAM (P11): Setting data for Body Fat involves selecting "BODY FAT Program" using the UP or DOWN key, then pressing ENTER. Follow the prompts to adjust gender, height, weight, and age using the UP or DOWN keys. Press START/STOP to begin measurement. After 15 seconds, the display will show Body Fat %, BMR, BMI, and BODY TYPE. Press START/STOP to return to the main display.

TARGET HEART RATE Program (P12): Select "TARGET H.R." using the UP or DOWN key, then press ENTER. Follow the same parameter setting process as in the Manual program. If the pulse is above or below the set TARGET H.R, the computer will adjust the resistance load automatically. Press START/STOP to begin the workout.

HEART RATE CONTROL Program (P13-P15): There are 3 target pulse selections:

P13- 60% TARGET H.R

P14- 75% TARGET H.R

P15- 85% TARGET H.R

Select one using the UP or DOWN key, then press ENTER. Follow the same parameter setting process as in the Manual program. If the pulse deviates from the TARGET H.R, the computer will adjust the resistance load automatically.

User Program (P16-P19): There are four user programs available (U1 to U4). Select a user using the UP or DOWN key, then press ENTER. Follow the same parameter setting process as in the Manual program. After setting desired parameters, the level 1 will flash. Use the UP or DOWN key to adjust, then press ENTER. Press START/STOP to begin the workout.

SETTING YOUR BIKE UP

Having your bike seat adjusted to the right height is essential for a comfortable ride, efficient pedalling and avoiding injury. There are 2 adjustments located on the seat post. The first is a vertical height adjustment, the second is for horizontal seat position. Although there are many methods and opinions on the optimal saddle setting, the following is a quick and easy method to get started. Further adjustments can be made afterwards to optimise your position and comfort.

Saddle Height Adjustment

Place your heels on the bike pedals and pedal backward. Your legs should be fully extended with your knees straight. If your hips rock from side to side while pedalling backward, the seat is too high. Place the ball of your foot on the pedal. There should now be a slight bend in your knee when the pedal is at its lowest point. This is a good starting point. Refer to examples below.



Seat Adjustment

Ensuring you have the most comfortable riding position whilst minimising joint strain is important. Adjusting your seat is simple and can normally be done without needing to get off the bike.

Place your heel on one of the bike pedals and rotate to the furthest point on the pedal stroke (as shown) You may need to remove the toe strap to do this. If the leg is still in the bent position, unlock the seat mechanism and adjust to the fully extended position (Pic.1) – Lock the seat adjustment mechanism in to place.

Moving your foot backwards, place your forefoot on to the pedal in the correct riding position. This should allow for a natural bend in the knee, whilst providing a full 360 degree rotation. If you experience the feeling of reaching for the pedal or sliding down the seat, you may need to make a minor adjustment to the position. Before commencing your workout please reattach and adjust the toe strap correctly to secure your foot firmly on the pedal.”

Note: - If you are using the exercycle for injury rehabilitation purposes i.e. Knee Replacements you may need to extend the seat position further than normal to allow for any reduced joint mobility due to swelling and inflammation

SETTING YOUR BIKE UP

- Whilst sitting on the seat, bring your left crank arm around and have your helper stop the crank when the pedal is at three o'clock or parallel with the floor. For this measurement to be accurate, your shoes must be correctly positioned on the pedals (the balls of your feet should be over the pedal axles).
- Holding this position, have your helper place the end of the plumb line on the front of your leg, at a point just below the bony protrusion beneath the kneecap.
- The plumb line's weight should hang over your shoe. Check again to ensure that the crank-arm and pedal are level. By looking at the plumb line the knee should be in alignment with the centre spindle or axle of the pedal.
- Adjust the saddle to the correct position then tighten the locking pin.

CARE AND MAINTENANCE

⚠ WARNING

IMPORTANT INFORMATION

Before cleaning or carrying out any maintenance on your exercycle, ensure the power is turned off and the power cord removed from the plug socket.

Prolong the life of your exercycle by performing periodic maintenance checks. Not only does this ensure your machine is in full working order to ensure they continue to run smoothly and reliably, but it will save you service costs in the long run.

Cleaning

General cleaning of the unit after use will protect the bike's powder-coated framework and prevent unnecessary corrosion stains and damage to the structural components from sweat and perspiration.

Please ensure all sweat residue is wiped from any contact points or framework with a damp cloth using a suitable PH neutral detergent in water to avoid salt and corrosion deposits on your equipment. Failure or neglect to maintain and clean sweat residue from the bike frame may affect any frame warranty implied.

Frame and Pedals

Check all nuts and bolts securing the framework, seat and handlebar assemblies are tight.

Ensure the pedals are securely attached to the crank arms. When tightening pay attention to the reverse thread (tightening anti-clockwise) on the left hand pedal assembly, when sitting on the bike. Be careful not to strip or force the pedal thread when tightening.

LIMITED WARRANTY

Warranty Range

Damage in correct maintenance and normal operations (not factitious factors). Warranty card to the original purchaser, shall not be transferred.

Warranty Time

HOME USE ONLY. This bike is not designed for commercial use.

- 10 Year Frame
- 1 Year Parts and Labour

The following conditions are not under warranty range:

- A) As a result of abuse, neglect, accident, or unauthorized modification;
- B) The damage due to incorrect adjustment of the machine;

Repair and Maintenance Service

Please contact our Elite Fitness Service Department at eliteservice@elitefitness.co.nz or visit www.elitefitness.co.nz for any service related issues or advice on preventative maintenance servicing procedures.

WARM-UP EXERCISE

Warm up exercise is important in preparing the muscles for activity whilst minimising the risk of injury. You may choose to warm up with a light/brisk walking pace for 5-10 minutes before stopping and performing some simple stretches. (As shown in the pictures below)

Hamstring Stretch (Standing)

Keep your knees slightly bent and slowly lean forward, back and shoulders relaxed, reaching towards your toes. You should feel the tension and slight discomfort in your hamstring muscles. Hold for 15-20 seconds. Repeat 2-3 times.

Hamstrings Stretches (Seated)

Sitting on the floor preferably on a mat, put one leg straight, the other inward and close to the inside of the straight leg. Lean forward from the hips, reaching towards your toes. Hold for 10-15 seconds, and relax. Repeat 3 times for each leg (See picture 2).

Crus and Feet Tendon Stretches

Standing with two hands on the wall or tree, one leg behind. Keeping your legs straight and the heel on the ground, lean forward towards the wall or tree. Hold for 10-15 seconds, and relax. Repeat 3 times for each leg (See picture 3).

Quadriceps Stretches

Keeping your balance with your left hand holding onto a wall or stationery fixture, grasp your right foot with your right hand and stretch your right heel toward your buttocks slowly, until you feel the stretch in the front of your thigh. Hold for 10-15 seconds, and relax. Repeat 3 times for each leg (See picture 4).

Sartorius (Inner Muscles of the Thigh) Muscle Stretches

Sitting down with the soles of your feet or shoes together and your knees positioned outward. Pull your feet towards your groin until you can feel the stretch. Hold for 10-15 seconds, and relax. Repeat 3 times (See picture 5).

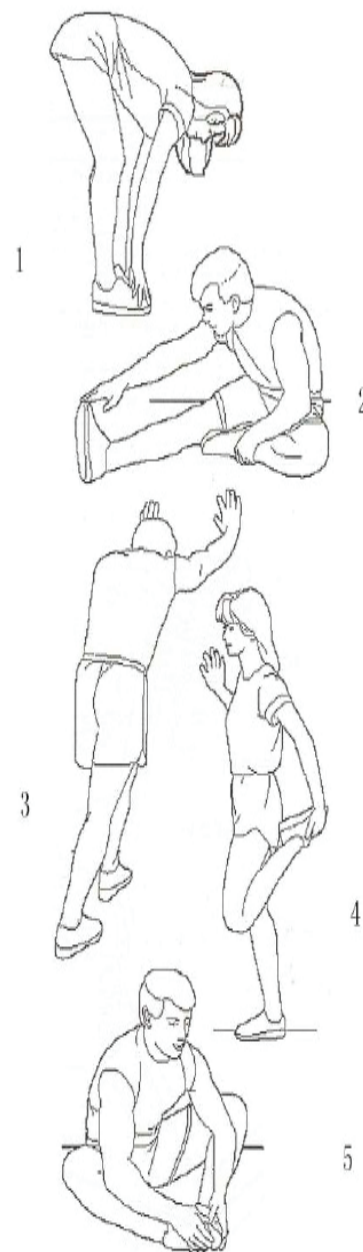

TRAINING STAGES

		Exercise Zone									
		AGE									
Beats Per Minute	100%	200	195	190	185	180	175	170	165	155	150
	VO2 Max (Maximum Effort)	180	176	171	167	162	158	153	149	140	135
	Anaerobic (Hardcore Training)	160	156	152	148	144	140	136	132	124	120
	Aerobic (Cardio Training/Endurance)	140	137	133	130	126	123	119	116	109	105
	Weight Control (Fitness/Fat Burn)	120	117	114	111	108	105	102	99	93	90
	Moderate Activity (Maintenance/Warm up)	100	98	95	93	90	88	85	83	78	75
	50%										

Cardiovascular training plays an important part in maintaining a healthy heart and lung function, so it's no surprise we should be paying attention to how quickly our heart beats during exercise. The chart above outlines a range of heart rate training zones determined by the individual's age and workout goals to ensure you train safely and effectively.

Heart Rate can be measured by using the radial (wrist) or carotid (neck) pulse using your index and middle fingers, counting the beats for 10 seconds and multiplying by 6. Alternatively, the use of a Wireless Telemetry Heart Rate strap and watch will give you an accurate Beats Per Minute (BPM) reading.

$220 - \text{AGE} = \text{TMHR}$ (Theoretical Maximum Heart Rate)

$\text{TMHR} \times 85\% = \text{(Upper Training Limit) BPM}$

$\text{TMHR} \times 65\% = \text{(Lower Training Limit) BPM}$

Note: Contact heart rate may provide inaccurate readings and is designed only as a guide

Example: $220 - 39 = 181 \text{ BPM}$

$181 \times 85\% (0.85) = 154 \text{ BPM}$ (Upper Training Limit)

$181 \times 65\% (0.65) = 118 \text{ BPM}$ (Lower Training Limit)



For more information about our Elite exercise equipment or other brands that we stock for your home, visit www.elitefitness.co.nz

Copyright © 2024 Elite Fitness

Elite Fitness, 28 Morrin Road, Saint Johns, Auckland, New Zealand.
0800 243 834, www.elitefitness.co.nz

Keep up to date with the latest products, competitions and equipment, follow us on our social media sites.



[@EliteFitnessNZ](https://www.instagram.com/EliteFitnessNZ)

[@EliteFitnessTV](https://www.youtube.com/EliteFitnessTV)