

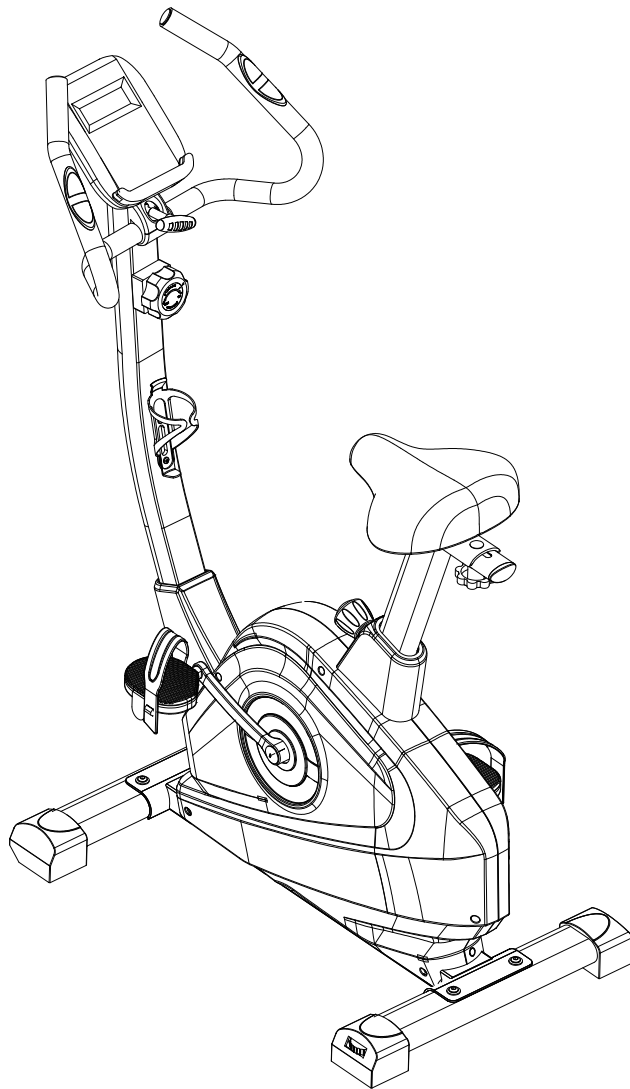

ASSEMBLY MANUAL >

ASTRA SL

UPRIGHT BIKE



Record serial number

Elite ASTRA SL Exercycle

Thank you for purchasing the **Elite Astra SL Exercycle**.

For over 30 years, Elite Fitness™ has been New Zealand's largest supplier of fitness equipment. Our aim and vision is to provide you Elite™ branded products, tested to the highest standard for quality and biomechanics at the best possible price.

Please read through this manual to familiarise yourself with the operation of your new **Elite Astra SL**. Doing so will help to ensure that you get the most out of your machine, enjoying safe and effective workouts ahead.

Even though we go to great efforts to ensure the quality of each product we produce, occasional errors and or omissions do occur. In any event should you find this product to have either a defective or a missing part, please contact us for a replacement.

SERVICE & WARRANTY

For service and warranty assistance please visit:

www.elitefitness.co.nz/service

Online forms are available for Service, Warranty and Parts requests.

(09) 258 9067

Elite Fitness HQ

28 Morrin Road

St Johns

Auckland, New Zealand

info@elitefitness.co.nz

0800 2 438 348

CONTENTS

Important Safety Instructions	3	Care and Maintenance	17
Product Specifications	4	Maintenance Log	18
Hardware Package	5	Limited Warranty	19
Parts List	6	Warm-Up Exercise	20
Assembly Instructions	7	Training Stages	21
Exploded Drawing	13	Notes	22
Seat Adjustment	14		
Console Display	15		

IMPORTANT SAFETY INSTRUCTIONS

The following definition applied to the word “WARNING” when used in this manual:



WARNING

Used to call attention to POTENTIAL hazards that could result in personal injury.

READ ALL INSTRUCTIONS BEFORE USING THE MACHINE

This product has been designed for **home use only**. Product liability and warranty conditions will not be applicable to products being subjected to professional use or products being used in a commercial environment. e.g Gym Centre, Retirement Centre, Home Based PT Studio and Physio.

This exercise machine is built for optimum safety. However, certain precautions apply whenever you operate a piece of exercise equipment. Be sure to read the entire manual before you assemble or operate your machine. In particular, note the following safety precautions.

- Read all instructions in this manual before using this equipment.
- Use the machine only for its intended use as described in this Manual.
- Inspect and tighten all the loose parts before this equipment is used.
- Keep hands away from moving parts.
- Keep children and pets away from the machine at all times. **DO NOT** leave children unattended in the same room with the machine.
- Before using the machine to exercise, always do stretching exercises to properly warm up.
- Inspect the machine before each use; make sure all of the connections are tightly secured.
- Only one person at a time should use the machine.
- If the user experiences dizziness, nausea, chest pain, or any other abnormal symptoms, **STOP** the workout at once. **CONSULT A PHYSICIAN IMMEDIATELY.**
- Position the machine on a clear, levelled surface. **DO NOT** use the machine near water or outdoors.
- Always wear appropriate workout clothing when exercising. **DO NOT** wear robes or other clothing that could become caught in the machine. Sporting shoes are recommended when using the machine.
- Do not place any sharp object around the machine.
- Disabled persons should not use the machine without a qualified person or physician in attendance.
- Never operate the machine if the machine is not functioning properly.
- Only carry out training work on the equipment when it is in perfect working order. Only use original spare parts in the event of a repair.
- Do not use strong solvents for cleaning, and only use the tools supplied, or suitable ones of your own, for any repairs that may be required. Please dispose of the packaging and any parts that have to be replaced subsequently (all parts for the unit) at suitable collecting points or containers with a view to saving the environment.
- **DO NOT** extend the seat stem past the warning line “Max” when adjusting the seat height.
- Not for therapeutic use.

WARNING: Before beginning any exercise programme, consult your physician. This is especially important for persons with pre-existing health problems. The seller assumes no responsibility for personal injury or property damage sustained by or through the use of this product.

SERVICE HINTS: The high quality standard of this product only will be kept if you, on a regular basis, check all screw connections and moving parts on proper fitting. Damaged parts need to be changed immediately. During the time of repair the product must not be used by anybody.

IMPORTANT HINTS:

- A) This product has been tested in accordance with the requirements of EN 957-1/A1, EN 957-5, standard, Class HA (HOME USE). The maximum load is limited to 120 KGS.
- B) Parents should be aware of the risk factor of young children playing on fitness equipment unattended. Make sure that children are instructed properly in the use of the product and in the controlled execution of the different exercises. Misuse of the product could result in serious injury.

PRODUCT SPECIFICATIONS

User Weight Capacity:	120 kg
-----------------------	--------

Shipping Weight:	29.2 kg
------------------	---------

Net Weight:	26.7 kg
-------------	---------

HARDWARE PACKAGE

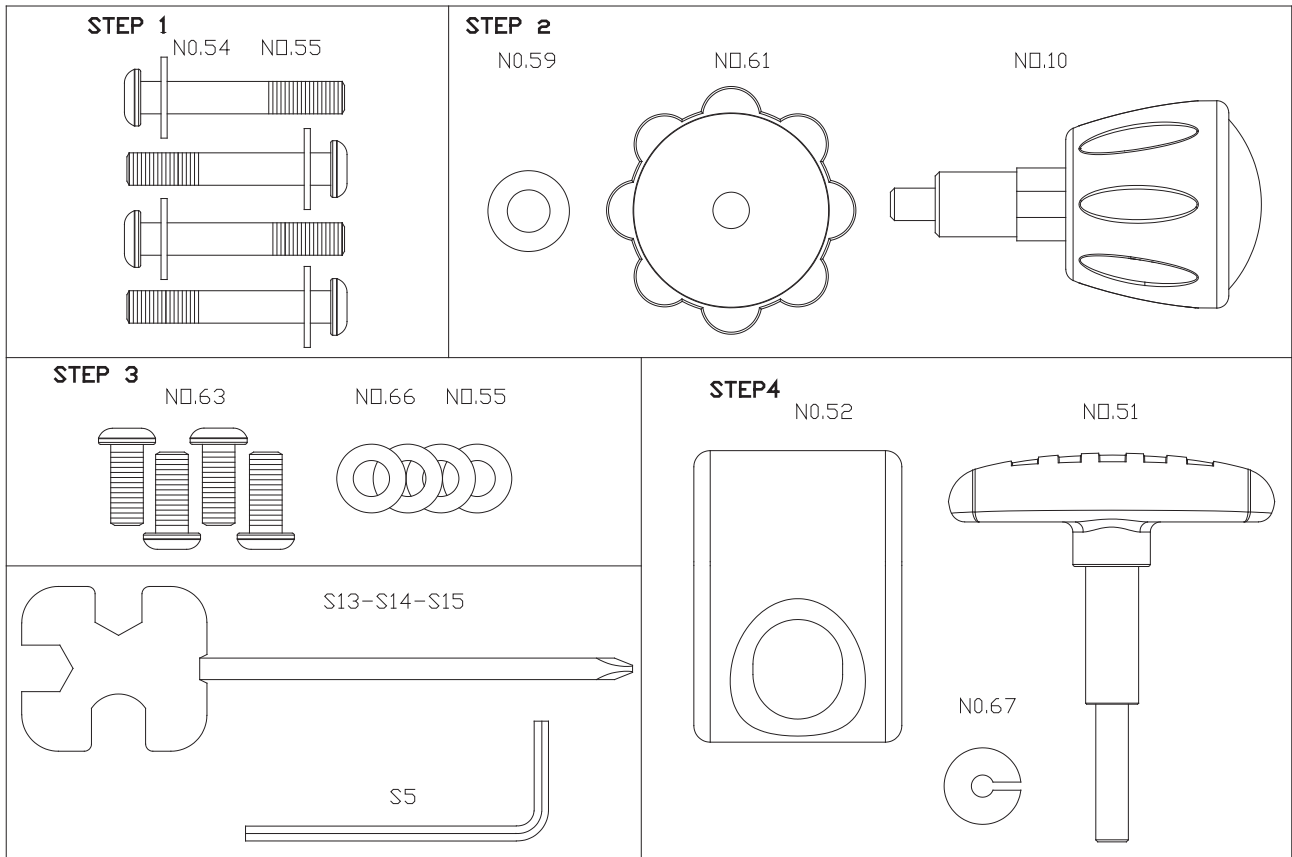

PARTS LIST

NO.	NAME/SPECIFICATION	QTY	NO.	NAME/SPECIFICATION	QTY
1	Main Frame	1	43	Tension Spring	1
2	Rear Stabiliser	1	44	Axle of Rotation	1
3	Front Stabiliser	1	45	Circlip	2
4	Saddle Support Post	1	46	Screw	6
5	Saddle	1	47	Axis of Flywheel	1
6	Saddle Post Decorative Cover	1	48	Bearing Block	2
7	Front Post	1	49	Bearing 6001	2
8	Handle Bar	1	50	Bearing End Cap	2
9	Console	1	51	T-Shape Knob	1
10	Adjusting Knob	1	52	Decorative part	1
11L	Pedal(L)	1	53	Screw	8
11R	Pedal(R)	1	54	Screw	4
12	Front Stabilizer Tube Plug(L)	1	55	Flat Washer	6
13	Rear Stabilizer Tube Plug	2	56	Saddle Sliding Group Set	1
14	Console Wire(Top)	1	57	Screw M5X16H	2
15	Screw	1	58	Square Tube Plug	2
16	Speed Sensor Wire	1	59	Flat Washer	1
17	Resistance Adjusting Set	1	60	Nylon Nut	3
18	Resistance adjusting Wire(Bottom)	1	61	Knob	1
19	Pulse Sensor Wire	2	62	Tube Plug of Handle Bar	2
20	Handle Pulse Sensor	2	63	Screw	4
21	Curved Washer	1	64	Flat Washer	3
22	Tube Bushing	1	65	Screw	9
23	Flywheel	1	66	Curved Washer	2
24	Left Cover	1	67	Protective plug	2
25	Right Cover	1	68	Screw	4
26	Pulley Axle welding Group	1	69L	Left crank	1
27	Belt Pulley	1	69R	Right crank	1
28	Front Post Decorative Cover	1	70	Locking Piece	2
29	Decorative Circle Cover	4	71	Crank End Cap	2
30	Front Stabilizer Tube Plug(R)	1	72	Bearing	2
31	Crank Cover	2	73	Pulley Axle Spacer Bush	1
32	Nylon Nut	2	74	Hex nut	2
33	Belt	1	75	Hex screw	1
34	Tension Spring	1	76	Circlip	1
35	U Bracket	1	77	Foam	2
36	Screw	8	78	Flat Washer	2
37	Pinch Roller Screw	1	79	Flywheel retainer	2
38	Pinch Roller	1	80	Hexagon head bolt	4
39	Idler Shaft Bushing	1	81	Screw	6
40	Flat Washer	2	82	Trim Cover	6
41	Screw	1	83	Water bottle rack	1
42	Magnet Board	1			

ASSEMBLY INSTRUCTIONS

STEP 1

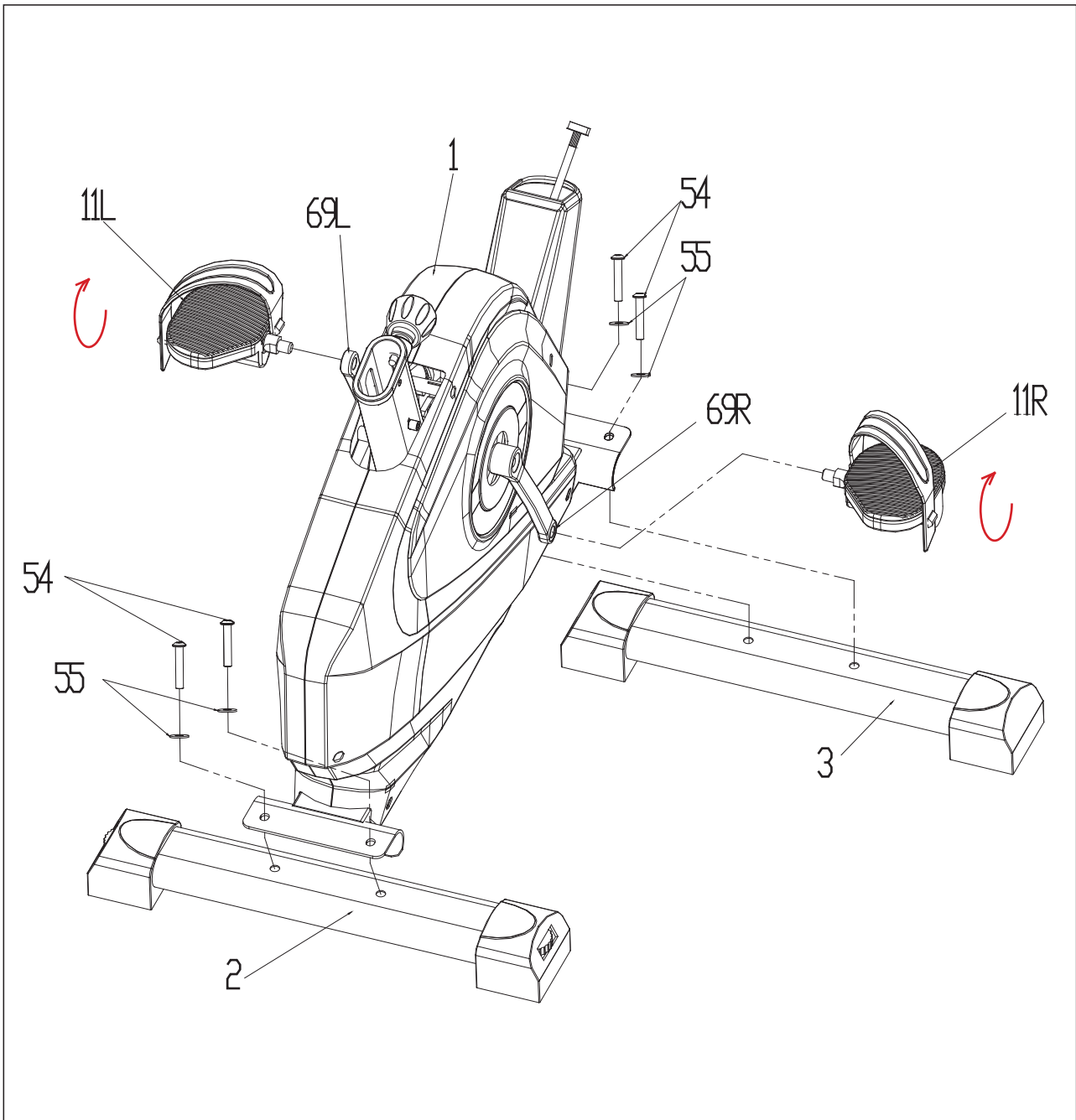

Connect the front stabiliser (3) and the rear stabiliser (2) to the main frame (1) using Screw (54) and flat washer (55). The front stabiliser (3) comes with a transport wheel, making it easier for you to move this equipment. The rear stabiliser does not have a wheel.

Securely fasten the pedal (11L/R) to the crank (69L/R) using the spanner tool. Ensure that the right pedal (11R) marked (R) is firmly attached to the right crank in a clockwise direction. Similarly, attach the left pedal (11L) marked (L) tightly to the left crank in an anticlockwise direction.

ASSEMBLY INSTRUCTIONS

STEP 2

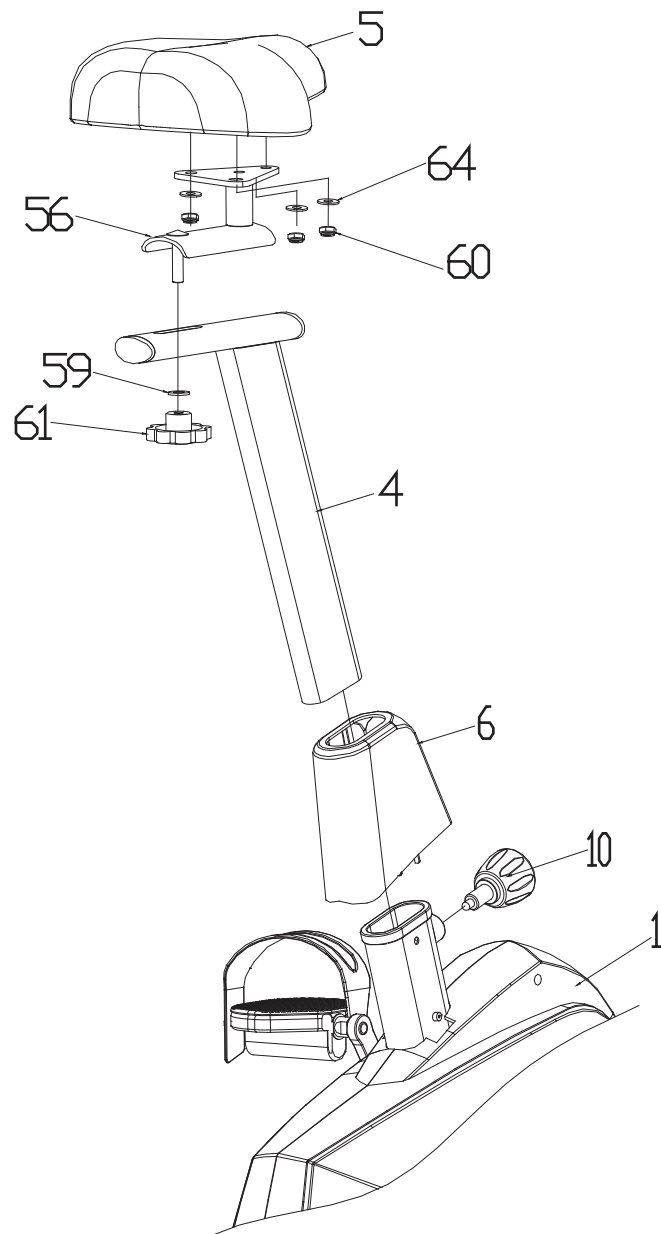

Fix the saddle (5) onto the saddle sliding (56) using a flat washer (64) and nylon nut (60), then securely tighten the saddle (5).

Insert the saddle and bracket into the vertical saddle support post (4) and position them at your preferred height. Align the holes and secure them in place using the knob (61) and flat washer (59).

Place the saddle support post (4) into the main frame (1) along with the saddle post cover (6), ensuring the holes are aligned. Secure the saddle in place using the adjusting knob (10). The correct saddle height can be adjusted once the bike is fully assembled.

Note: Ensure not to surpass the "stop" mark.

ASSEMBLY INSTRUCTIONS

STEP 3

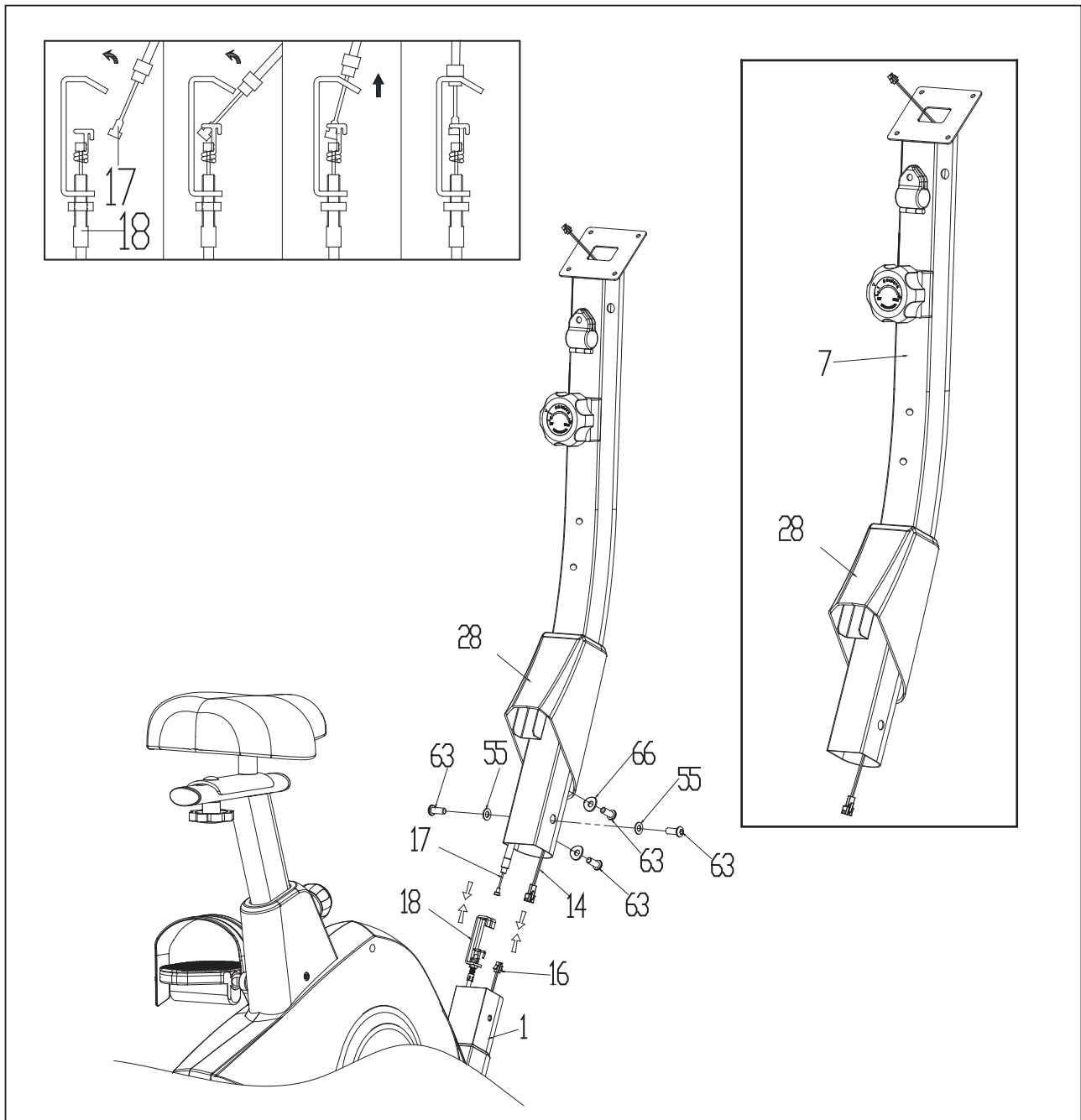

Insert the front post (7) into the front post cover (28) initially.

Join together the console wire (14) and speed sensor wire (16), at the same time, connect the resistance adjusting wire (17 & 18). Ensure that all the pins are straight when connecting. Failure to do so may lead to console malfunction.

Secure the front post (7) to the main frame (1) using screw (63), flat washer (55), and curved washer (66).

ASSEMBLY INSTRUCTIONS

STEP 4

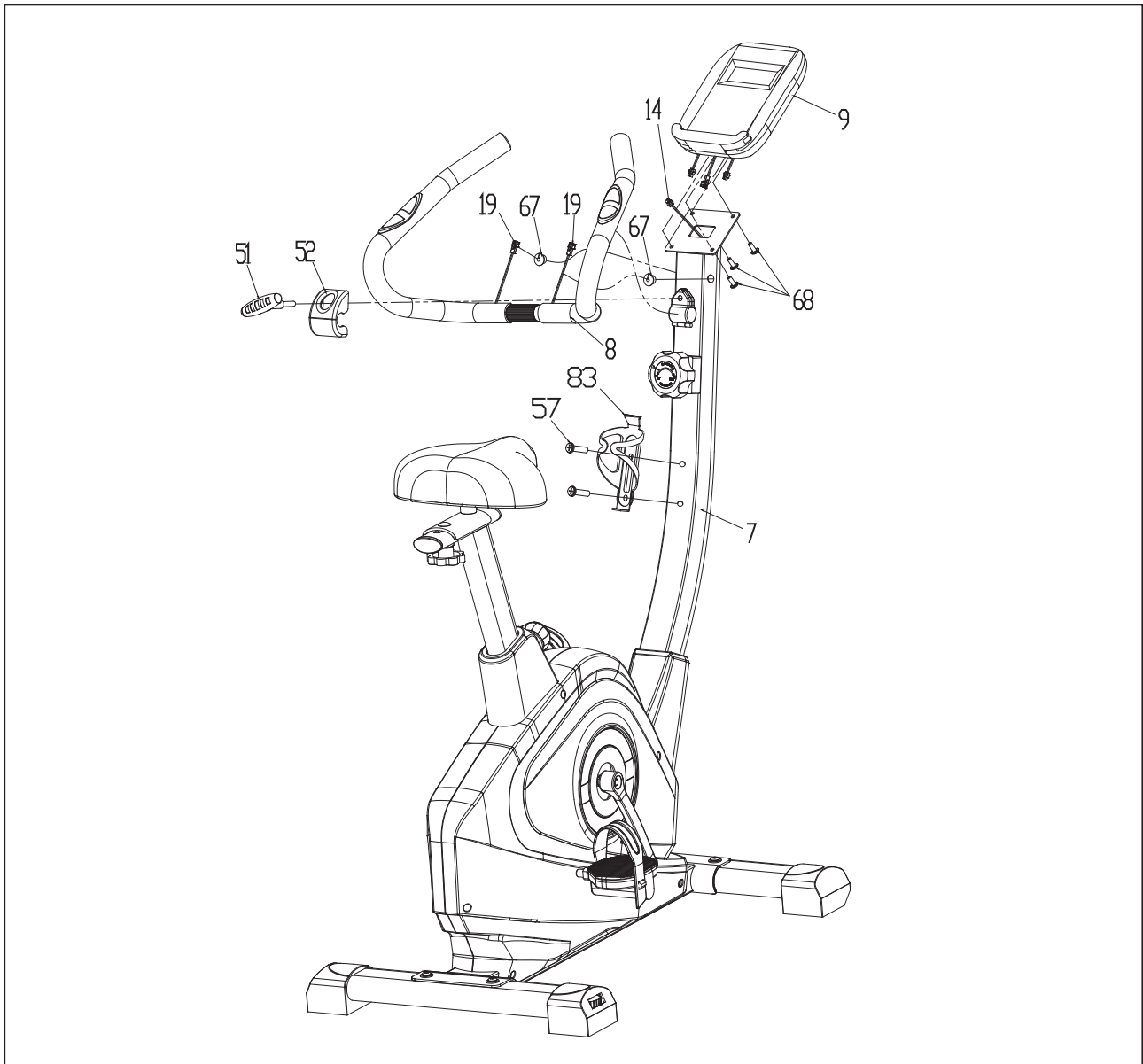

Fit the console (9) onto the front post (7) using the screws (68). Remove the protective plug (67), insert the pulse sensor wires (19) from the handlebar (8) into the hole on the front post (7), and then pull them out. Replace the protective plug (67) into the hole. Secure the handlebar (8) onto the handlebar fixing socket using the T-Shape knob (51) and decorative part (52) appropriately. Take care not to snag the pulse sensor wire connected to the handlebar, as it may affect heart rate measurement.

Ensure a secure connection by firmly joining the hand pulse sensor wires (19) and main console wires (14). Push any excess wires back down the stem until the console rests on the bracket.

Secure the water bottle cage (83) onto the front post (7) using the screws (57) and tighten them.

Note that all the fixings are preassembled to the back of the console when connecting it to the bracket. When you wish to use the exercise bike, insert the power adapter (18) into the power socket.

ASSEMBLY INSTRUCTIONS

CONGRATULATIONS

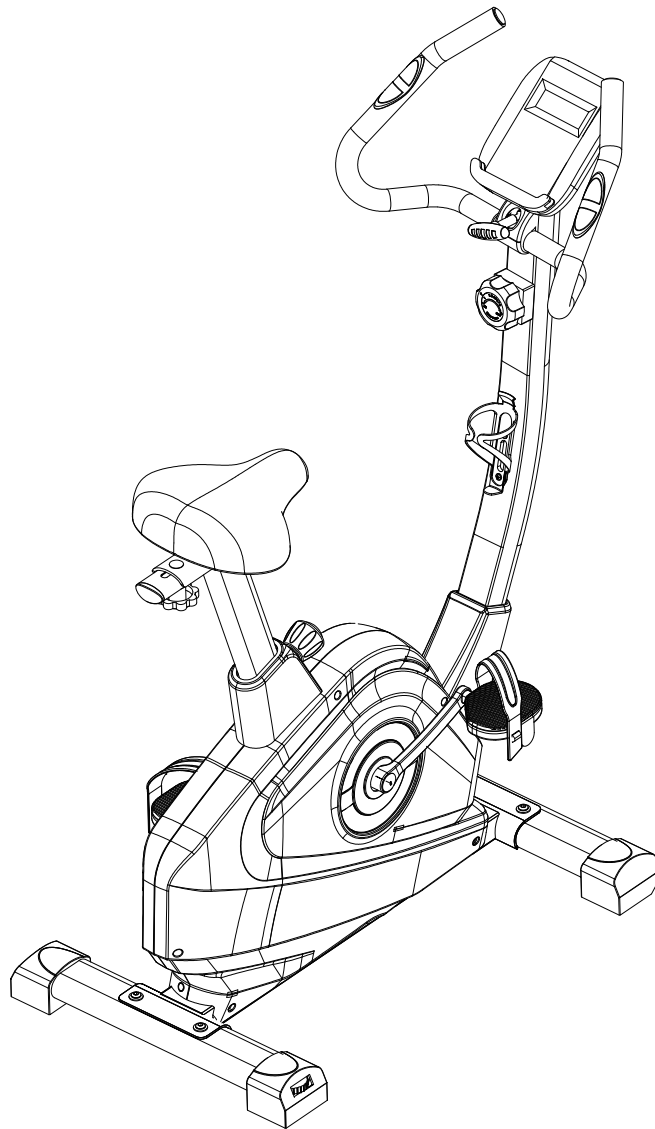

Assembly of your **Elite Astra SL Exercise** is now complete! Be sure to fully inspect your machine before using it for the first time.

⚠ WARNING

Failure to visually check and test the assembly of your exercise before use can cause damage to the exercise, serious injury to users and bystanders and can also compromise the effectiveness of your exercise program.

ASSEMBLY INSTRUCTIONS

HANDLING

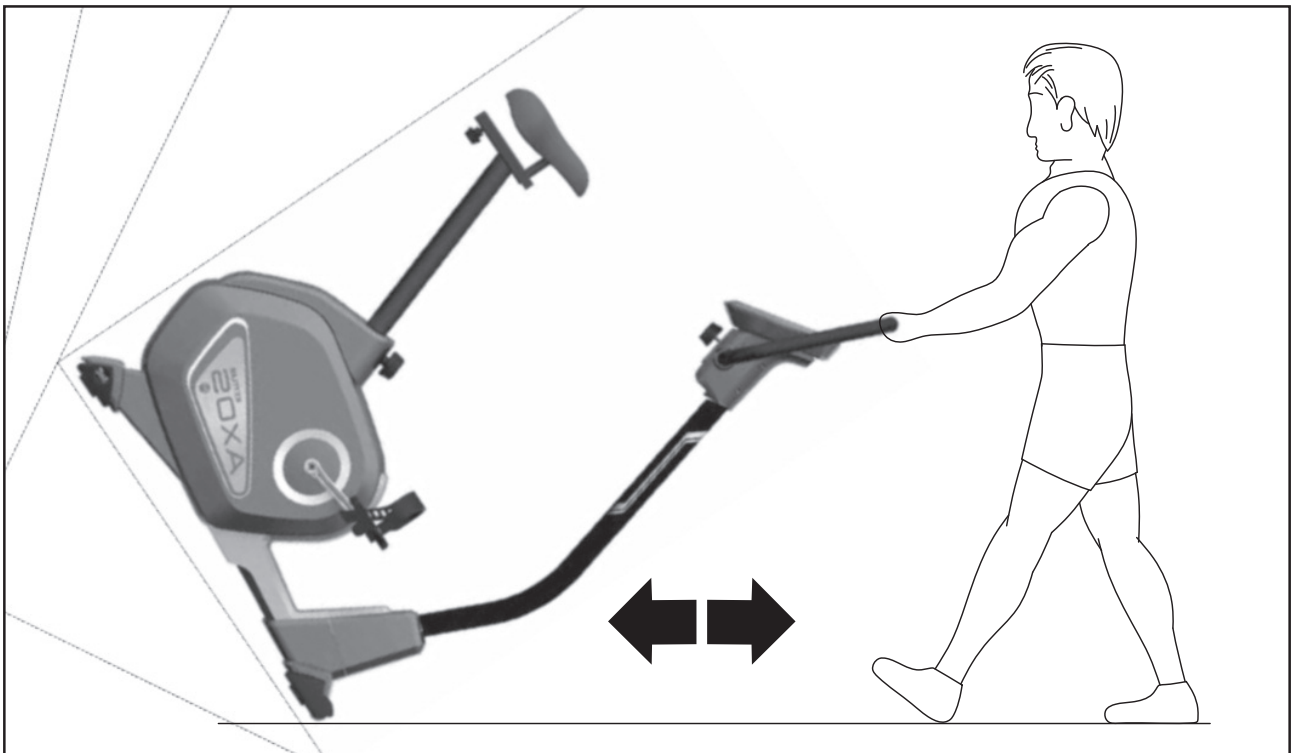
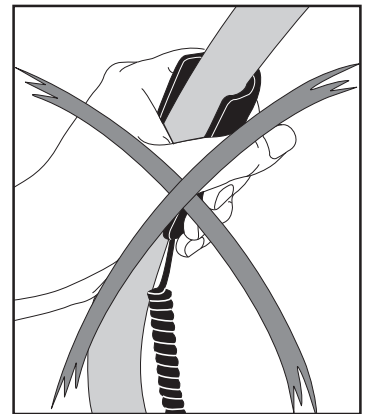
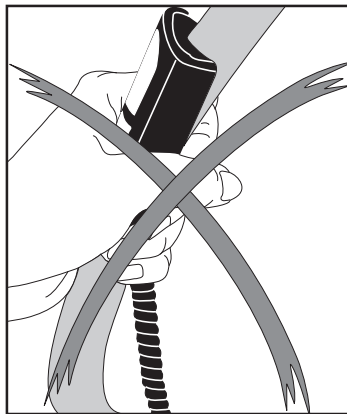
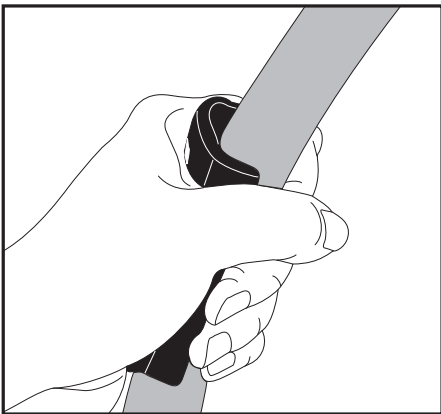
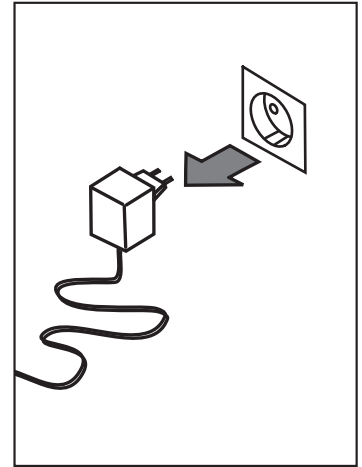

SEAT ADJUSTMENT



Saddle Height Adjustment

Having your bike seat adjusted to the right height is essential for a comfortable ride, efficient pedalling and avoiding injury. There are 2 adjustments located on the seat post. The first is a vertical height adjustment, the second is for horizontal seat position. Although there are many methods and opinions on the optimal saddle setting, the following is a quick and easy method to get started. Further adjustments can be made afterwards to optimise your position and comfort.

Saddle Height Adjustment

- Place your heels on the bike pedals and pedal backward. Your legs should be fully extended with your knees straight. If your hips rock from side to side while pedalling backward, the seat is too high.
- Place the ball of your foot on the pedal. There should now be a slight bend in your knee when the pedal is at its lowest point. This is a good starting point.



Adjusting the Seat Fore-and-Aft Position

Adjusting the Seat Fore-and-Aft Position

Once you've adjusted seat height, it's time to find the correct fore-and-aft position of the saddle. This determines where you sit in relationship to the crank set (where the pedals are attached), which helps decide how comfortable and efficient you'll be when riding. This also minimises stress to the knee by being in a more neutral position.

If you want to try to check the fore-and-aft setting at home, you will need a second person and a plumb line (a length of string with a nut or washer tied on the end will work fine).

Whilst sitting on the seat saddle bring your right crank arm around and have your helper stop the crank when the pedal is at three o'clock or parallel with the floor. Note that for this measurement to be accurate, your shoes must be correctly positioned on the pedals (the balls of your feet should be over the pedal axles).

DISPLAY CONSOLE

Functional Buttons:

MODE: Press down to select functions.

Press down for 2 seconds to reset time, distance, and calories.

SET: Used to set the values of time, distance, and calories when not in scan mode.

RESET: Press down to reset time, distance, and calories.

Functions and Operations:

SCAN: Press the "MODE" button to select the "TIME" function, at which point "SCAN" will appear on the left of the monitor, and the monitor will rotate through all 6 functions: time, speed, distance, odometer, calorie, and pulse. Each display will hold for 6 seconds. During the cyclic display of each function, press the "MODE" button once to remove "SCAN" and display the selected function. To return to "SCAN", press the "MODE" button to select the "TIME" function again. In "SCAN" mode, "SCAN" will continuously flash on the left of the monitor.

TIME: Displays the time from the start to the end of the exercise.

SPEED: Displays the current speed.

DISTANCE: Displays the distance from the start to the end of the exercise.

ODOMETER: Displays the total accumulated distance. After reinstalling the battery, the value will return to zero.

CALORIES: Displays the calories burned from the start to the end of the exercise.

PULSE: Measures the user's heart rate. Press the button to switch to the pulse function, and hold the two heartbeat sensors in both hands to measure the heart rate. (If the computer has wireless heartbeat function, please wear the wireless heartbeat chest belt before measuring the pulse rate.)

Remark: During pulse measurement, the initial measurement value may be higher due to contact jamming for the first 2-3 seconds, then it will return to normal level. The measurement value cannot be regarded as the basis of medical treatment.

Target Training Settings:

TIME Target Training Mode: Press the "MODE" button to switch to the "TIME" function, then press the "SET" button to set the target time. When the required time is reached, stop the button. Start using the machine, and the display will start counting down. When the countdown reaches zero, the time function flashes to indicate the completion of the training target. If you continue to train, the computer will automatically start counting up from zero.

DISPLAY CONSOLE

DISTANCE Target Training Mode: Press the "MODE" button to switch to the "DIST" function, then press the "SET" button to set the target distance. When the required distance is reached, stop the button. Start using the machine, and the display will start counting down. When the countdown reaches zero, the distance function flashes to indicate the completion of the training target. If you continue to train, the computer will automatically start counting up from zero.

CALORIE Target Training Mode: Press the "MODE" button to switch to the "CAL" function, then press the "SET" button to set the target calorie. When the required calorie is reached, stop the button. Start using the machine, and the display will start counting down. When the countdown reaches zero, the calorie function flashes to indicate the completion of the training target. If you continue to train, the computer will automatically start counting up from zero.

To modify the target data after setting or completion, press the "RESET" button to clear all settings, and then reset according to the previous description.

NOTE:

If the battery symbol on the display lights up, please replace the battery.

The monitor will automatically shut off if no signal is received after 2 minutes.

The monitor will auto power on when starting to exercise by pushing the button signal in.

When you stop exercising for 4 seconds, the display will stop calculating, and a "STOP" will be displayed on the screen. When you start exercising again, the display will automatically start calculating, and the "STOP" will disappear.

Specifications:

FUNCTION	SCAN	Every 6 seconds
	TIME	0:00~99:59
	SPEED	0.0~99.9 KM/H (MILE/H)
	DISTANCE	0.00~99.99 KM (MILE)
	ODOMETER	0~9999 KM (MILE)
	CALORIES	0.0~999.9 CAL
	PULSE	60~240 BPM
BATTERY TYPE	2pcs of SIZE –AA or UM –3	
OPERATING TEMPERATURE	0°C ~ +40°C	
STORAGE TEMPERATURE	-10°C ~ +60°C	

CARE AND MAINTENANCE



WARNING

IMPORTANT INFORMATION

Before cleaning or carrying out any maintenance on your exercycle, ensure the power is turned off and the power cord removed from the plug socket.

Prolong the life of your exercycle by performing periodic maintenance checks. Not only does this ensure your machine is in full working order to ensure they continue to run smoothly and reliably, but it will save you service costs in the long run.

Cleaning

General cleaning of the unit after use will protect the bike's powder-coated framework and prevent unnecessary corrosion stains and damage to the structural components from sweat and perspiration.

Please ensure all sweat residue is wiped from any contact points or framework with a damp cloth using a suitable PH neutral detergent in water to avoid salt and corrosion deposits on your equipment. Failure or neglect to maintain and clean sweat residue from the bike frame may affect any frame warranty implied.

Frame and Pedals

Check all nuts and bolts securing the framework, seat and handlebar assemblies are tight.

Ensure the pedals are securely attached to the crank arms. When tightening pay attention to the reverse thread (tightening anti-clockwise) on the left hand pedal assembly, when sitting on the bike. Be careful not to strip or force the pedal thread when tightening.

LIMITED WARRANTY

Warranty Range

Damage in correct maintenance and normal operations (not factitious factors). Warranty card to the original purchaser, shall not be transferred.

Warranty Time

HOME USE ONLY. This bike is not designed for commerical use.

- 10 Year Frame
- 1 Year Parts and Labour

The following conditions are not under warranty range:

- A) As a result of abuse, neglect, accident, or unauthorized modification;
- B) The damage due to incorrect adjustment of the machine;

Repair and Maintenance Service

Please contact our Elite Fitness Service Department at eliteservice@elitefitness.co.nz or visit www.elitefitness.co.nz for any service related issues or advice on preventative maintenance servicing procedures.

WARM-UP EXERCISE

Warm up exercise is important in preparing the muscles for activity whilst minimising the risk of injury. You may choose to warm up with a light/brisk walking pace for 5-10 minutes before stopping and performing some simple stretches. (As shown in the pictures below)

Hamstring Stretch (Standing)

Keep your knees slightly bent and slowly lean forward, back and shoulders relaxed, reaching towards your toes. You should feel the tension and slight discomfort in your hamstring muscles. Hold for 15-20 seconds. Repeat 2-3 times.

Hamstrings Stretches (Seated)

Sitting on the floor preferably on a mat, put one leg straight, the other inward and close to the inside of the straight leg. Lean forward from the hips, reaching towards your toes. Hold for 10-15 seconds, and relax. Repeat 3 times for each leg (See picture 2).

Crus and Feet Tendon Stretches

Standing with two hands on the wall or tree, one leg behind. Keeping your legs straight and the heel on the ground, lean forward towards the wall or tree. Hold for 10-15 seconds, and relax. Repeat 3 times for each leg (See picture 3).

Quadriceps Stretches

Keeping your balance with your left hand holding onto a wall or stationery fixture, grasp your right foot with your right hand and stretch your right heel toward your buttocks slowly, until you feel the stretch in the front of your thigh. Hold for 10-15 seconds, and relax. Repeat 3 times for each leg (See picture 4).

Sartorius (Inner Muscles of the Thigh) Muscle Stretches

Sitting down with the soles of your feet or shoes together and your knees positioned outward. Pull your feet towards your groin until you can feel the stretch. Hold for 10-15 seconds, and relax. Repeat 3 times (See picture 5).

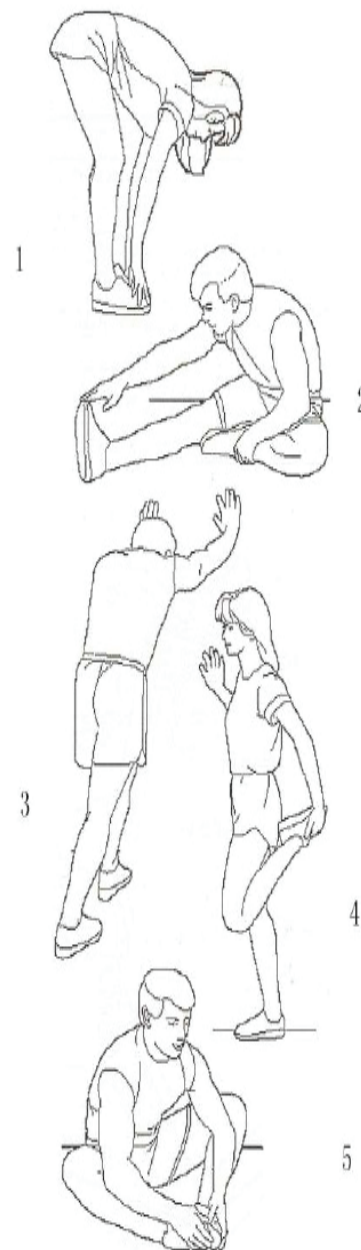

TRAINING STAGES

		Exercise Zone									
		AGE									
Beats Per Minute	100%	200	195	190	185	180	175	170	165	155	150
		VO2 Max (Maximum Effort)									
	90%	180	176	171	167	162	158	153	149	140	135
		Anaerobic (Hardcore Training)									
	80%	160	156	152	148	144	140	136	132	124	120
		Aerobic (Cardio Training/Endurance)									
	70%	140	137	133	130	126	123	119	116	109	105
	Weight Control (Fitness/Fat Burn)										
60%	120	117	114	111	108	105	102	99	93	90	
	Moderate Activity (Maintenance/Warm up)										
50%	100	98	95	93	90	88	85	83	78	75	

Cardiovascular training plays an important part in maintaining a healthy heart and lung function, so it's no surprise we should be paying attention to how quickly our heart beats during exercise. The chart above outlines a range of heart rate training zones determined by the individual's age and workout goals to ensure you train safely and effectively.

Heart Rate can be measured by using the radial (wrist) or carotid (neck) pulse using your index and middle fingers, counting the beats for 10 seconds and multiplying by 6. Alternatively, the use of a Wireless Telemetry Heart Rate strap and watch will give you an accurate Beats Per Minute (BPM) reading.

$220 - \text{AGE} = \text{TMHR}$ (Theoretical Maximum Heart Rate)

$\text{TMHR} \times 85\% =$ (Upper Training Limit) BPM

$\text{TMHR} \times 65\% =$ (Lower Training Limit) BPM

Note: Contact heart rate may provide inaccurate readings and is designed only as a guide

Example: $220 - 39 = 181$ BPM

$181 \times 85\% (0.85) = 154$ BPM (Upper Training Limit)

$181 \times 65\% (0.65) = 118$ BPM (Lower Training Limit)



For more information about our Elite exercise equipment or other brands that we stock for your home, visit www.elitefitness.co.nz

Copyright © 2024 Elite Fitness

Elite Fitness, 28 Morrin Road, Saint Johns, Auckland, New Zealand.
0800 243 834, www.elitefitness.co.nz

Keep up to date with the latest products, competitions and equipment, follow us on our social media sites.



[@EliteFitnessNZ](https://www.instagram.com/EliteFitnessNZ)

[@EliteFitnessTV](https://www.youtube.com/EliteFitnessTV)